

# PRO EASY 60000

## TROUBLESHOOTING THE FRIDGE



## The Refrigeration Unit

The Refrigeration unit is totally separate from the machine body - this is in order to allow for the quickest possible repair or replacement.

When investigating a fault - the following should be considered:

- The **condenser fan and evaporator (tangential)** rotate correctly.
- The **compressor** is working (vibrations).
- The **Inverter board** is correctly working.

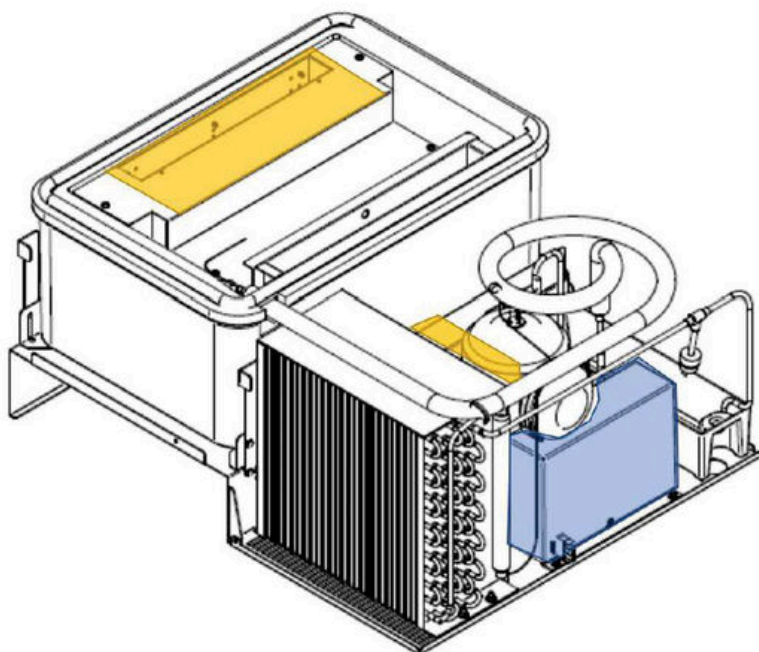

- Sealed circuit
- Inverter (electronic part)
- Ventilators (electrical parts)

# PRO EASY 6000

Westomatic

## The Inverter Board

The Inverter Board is located on the side of the refrigeration unit, when the machine is located within the machine.

To locate - slide the product tray out to reveal the fridge, and then look at the LED lights displayed on the Inverter board.



**USING FLAT HEAD - TURN ANTICLOCKWISE TO ACCESS FRIDGE**



**Colour LED lights:  
RED  
YELLOW  
GREEN**

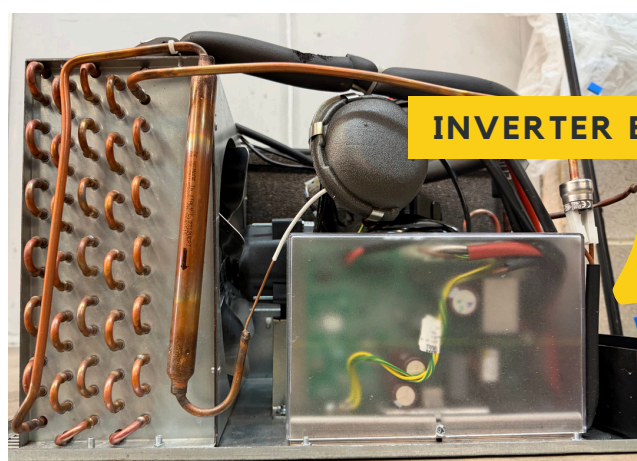

**INVERTER BOARD**

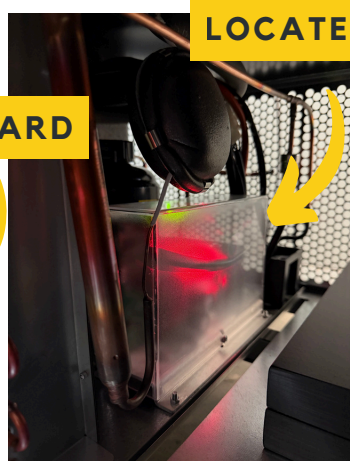

**LOCATE INVERTER BOARD**

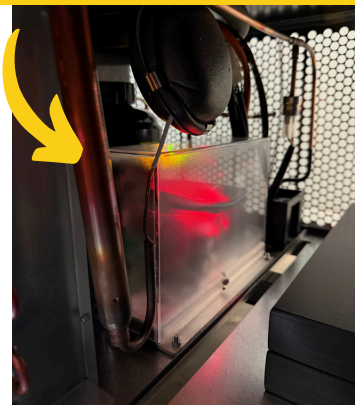

# PRO EASY6000

westomatic

Within the Machine Parameter / Cooling Unit settings in programming mode is an option to view the 'Fridge Monitor' which confirms the operation of the Inverter board - inputs and outputs to control the 'fridge unit'.

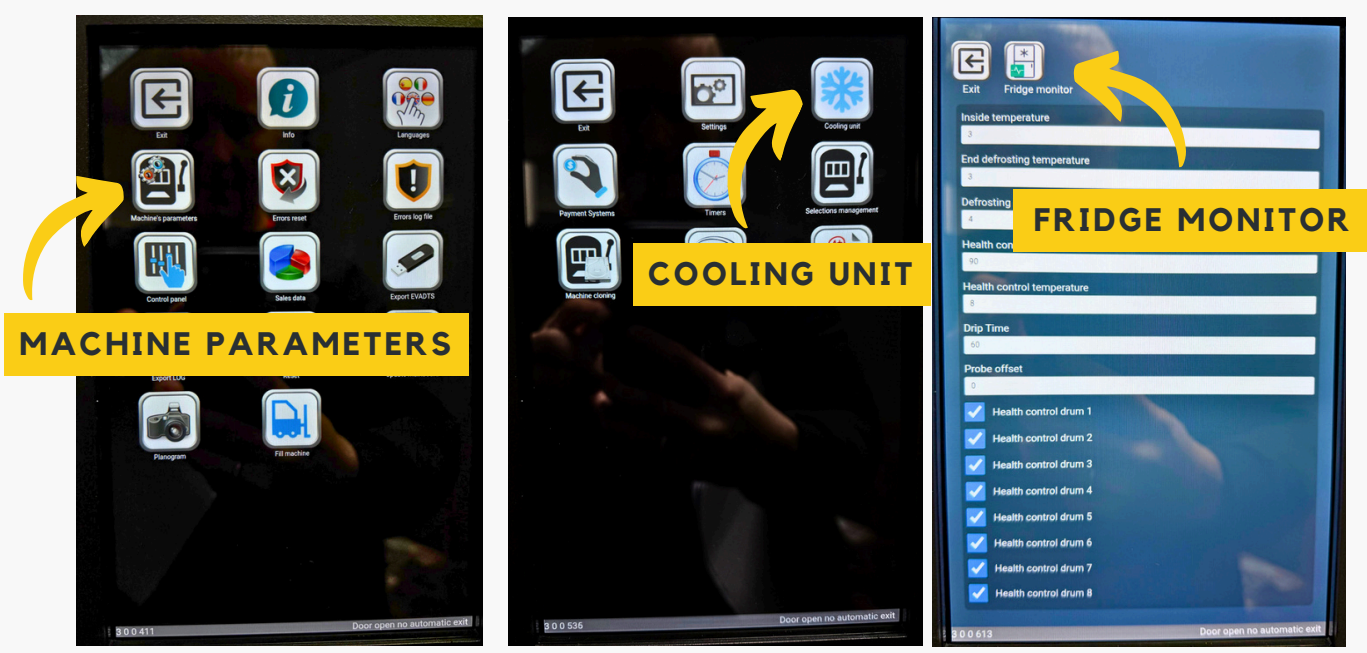

If the 'Fridge Monitor' page shows that the Inverter Board is not reporting any information at all (it shows 0 Volts and Zero for everything else) it is very unlikely to be the fridge itself at fault.

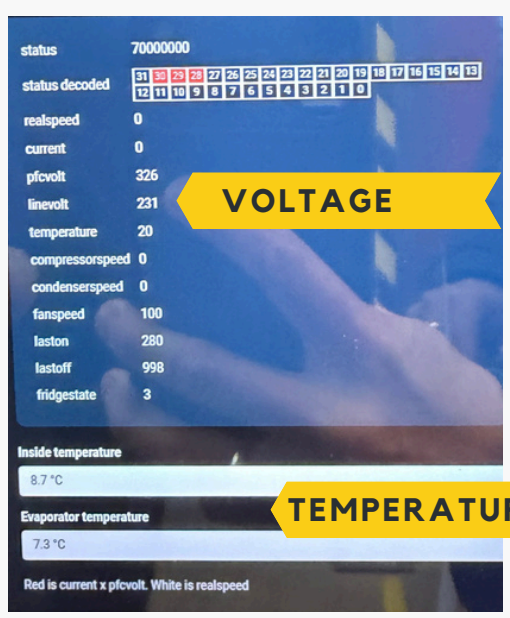
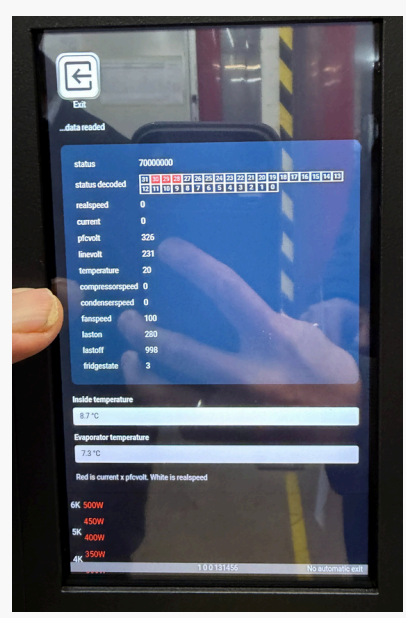

## **This could be due to:**

If the machine is powered up and the door is open:

- If no lights are seen on the fridge inverter board there is no 230V supply to the fridge unit.
  - Check the white plug from fridge is fully connected. Is there 230V between Brown and Blue wires in the plug?
  - If not check the 8Amp fuse.
- If the correct lights (as per the Inverter Board LED map) are seen on the inverter board it is likely that either:
  - The communication cable (small 4-way plug from fridge) is not correctly connected to the Power Supply Box - try disconnecting & re-connect again. [Check the Fridge monitor page to see if information is now being reported.](#)
  - The 4Amp fuse on the inverter board has blown. [Remove inverter board cover and the fuse itself to check. Replace fuse if necessary and re-test.](#)

# PRO EASY6000

**YELLOW:** LED - DL4    **RED:** LED - DL5    **GREEN:** LED - DL6

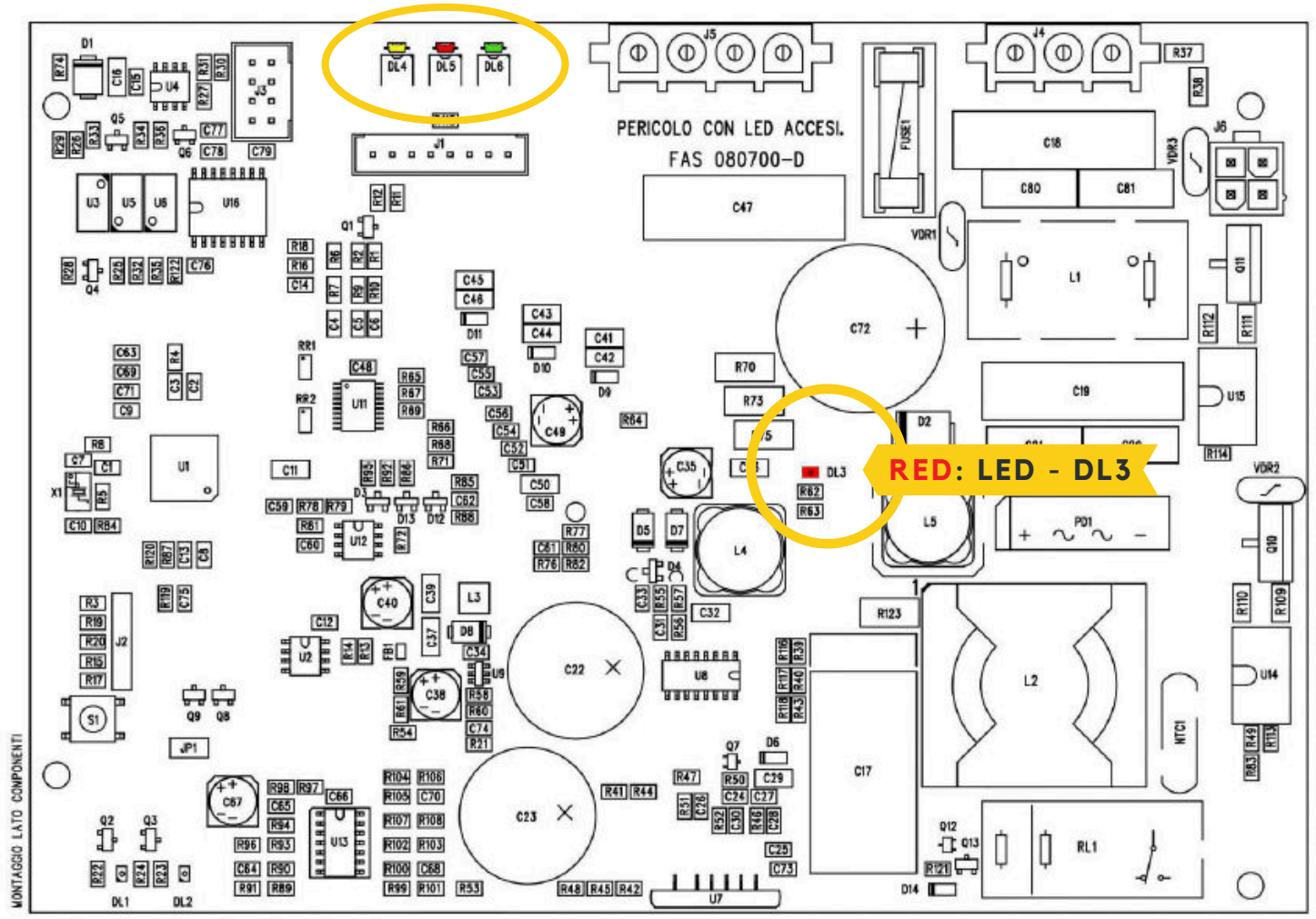

# PRO EASY6000

westomatic

## **GREEN: LED - DL6**

Always on: DC power supply is OK.

## **YELLOW: LED - DL4**

Flashing at 0.5 Hz (1 sec ON, 1 sec OFF):

Machine & Inverter board programs are running and Compressor/Condenser Fan have stopped – flashing at this rate represents fridge is in normal cut out condition (Cabinet programmed temperature has been reached).

If however the machine requires chilling and this condition exists, the Inverter Board could be faulty.

Flashing at 2 Hz (0.25 s ON, 0.25 s OFF):

Machine & Inverter board programs are running and Compressor/Condenser Fan running. This represents normal operation and the Evaporator should be chilling. If the cabinet doesn't chill and the evaporator tubes are warm, there could be a refrigerant leak from the system.

## **RED: LED - DL5**

**OFF:** Everything is OK.

**Always ON:** Motor fault - indicates a problem with the inverter board or compressor.

**FLASHING:** Motor protection active. 2 possible causes:

- Mains Voltage: less than 180V or greater than 265V - [Check entering current.](#)
- Inverter Overheated (over 90°C) - external temperature is too high or inverter board is faulty.

When in protection mode the compressor does not run. Once voltage returns to correct range and inverter returns to below 60°C the compressor will resume normal operation.

## Frozen Fridge

### CAUSES

External climatic conditions unsuitable for operation - ie. too hot and high humidity (>32°C & 65% humidity).

Air Infiltrations.

Malfunctioning Evaporator tangential fan.

### SOLUTIONS

Install the machine in an air-conditioned area.  
Allow machine to return to operating temperature.  
Use reinforced cooling unit - 840242.

Check fridge gasket - look for damage or a poor seal.



GASKET

Check if air comes out of the holes, extract the fridge a little while it is running (press door micro) and check if the tangential ventilator turns.



EVAPORATOR FAN

## Frozen Fridge (cont.)

### CAUSES

Wrong software settings.

### SOLUTIONS

Check defrost settings in Machine Parameters / Cooling Unit:

- End Defrosting temperature = 3°
- Defrosting cycles frequency = 4 (per hour).

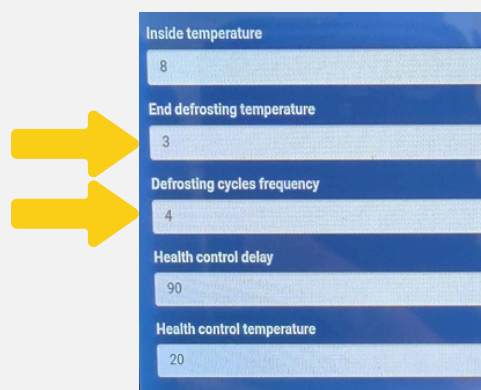

Evaporator probe faulty.

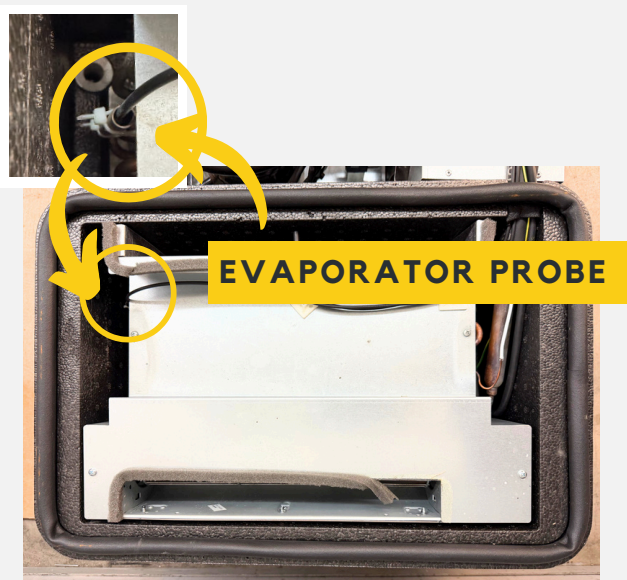

Check for Error code 11 - replace Evaporator probe.

When Evaporator Probe is faulty, defrost turns to time.

Refrigeration unit will require disconnecting for a minimum 12 hours to allow to totally defrost.

Measure resistance of both temperature probes, if either are outside the 800-1000Ω range, replace the probe.

## Compressor does not start

### CAUSES

Inverter Board broken.

### SOLUTIONS

Check Inverter board LEDs and check LED error lights and solutions.  
Replace Inverter Board if found faulty.

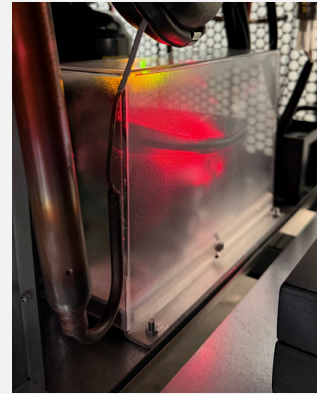

## Fridge does not cool - but components are OK.

### CAUSES

Finished or Insufficient cooling gas - possible leak on the circuit.

### SOLUTIONS

Touch the pipes - the one leading to the liquid box must be **hot** and the one leaving the compressor must be **cold**. In the CO2 fridge unit - the leak would empty the unit immediately due to the high pressure - so the gas loss would be evident.

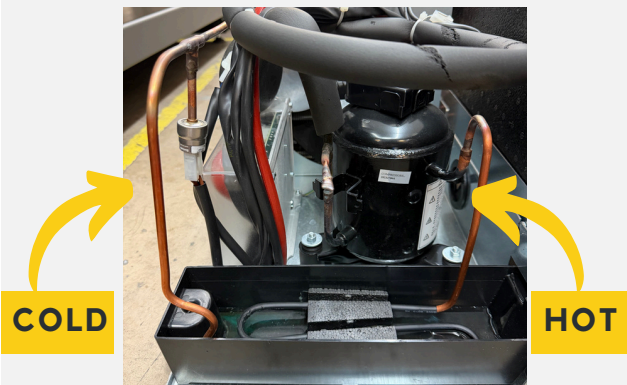

Ambient / Evaporator probes reversed.

Check probe connection and reverse/swap if incorrect.

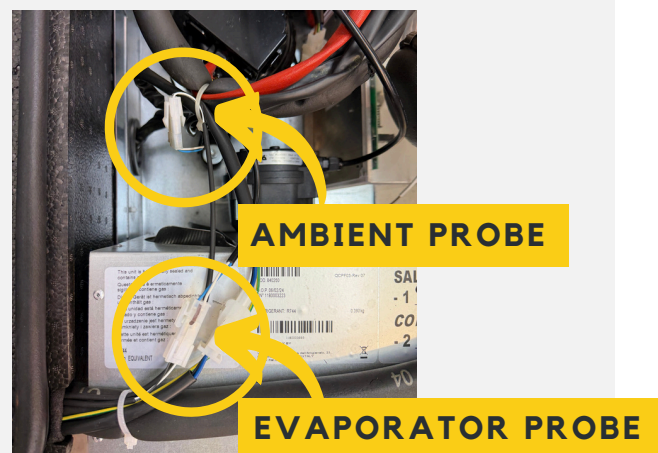

## Fridge safety intervention

### CAUSES

External climatic conditions unsuitable for operation - ie. too hot and high humidity (>32°C & 65% humidity).

Health control triggers fridge intervention for perishable products.

Loading of products at temperatures higher than HACCP procedures (Health Control).

### SOLUTIONS

Install the machine in an air-conditioned area.

Allow machine to return to operating temperature.

Remove perishable items.

Load products at the storage temperature set in the machine at the command 41.

Ensure that when machine is being filled that the main door is not open for a longer period that is necessary allowing the cabinet temperature to rise unnecessarily.

Ensure machine is being filled with pre-chilled products.

Check operation of evaporator fan circulating cold air from evaporator into cabinet.

Check evaporator is not freezing up – this would restrict cold airflow into the cabinet, allowing temperature to rise.

## Fridge safety intervention

### CAUSES

Machine left too long with the door open.

Wrong software settings.

Prolonged power off with door closed.

### SOLUTIONS

Hurry up and fill the machine!!  
Refill the machine within 15 minutes maximum.

Review software settings in Machine Parameters / Cooling Unit:

- Inside Temp = 8-10°C

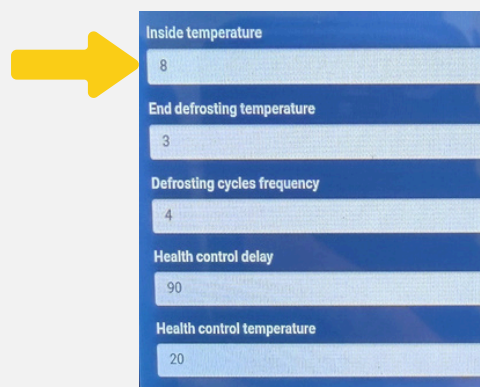

Check the power line to which the machine is connected and, if necessary, install the machine under an uninterruptible power supply.

## Fridge safety intervention

### CAUSES

Malfunctioning refrigeration unit.

### SOLUTIONS

Overhaul refrigeration unit - CLEAN!

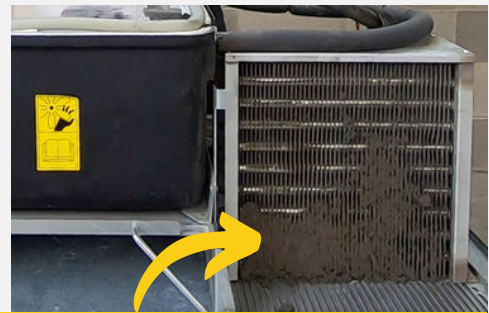

**REMOVE EXCESS DIRT/DUST**

Defective probe

Check probe resistance - range  $800\Omega$  -  $1100\Omega$ .

Replace probes if defective.

