



Vision

GUARANTEE

The manufacturer guarantees its machines as defined by the General Sales Condition for mechanical faults. Damage resulting from incorrect machine use is not covered by the warranty. For more information, read the General Sales Conditions. The manufacturer reserves the right to alter the characteristics of the equipment presented in this document without prior warning. The manufacturer also disclaims all responsibility for any possible inaccuracies in the document due to printing or copying errors...

FAS INTERNATIONAL S.p.A.
Via Lago di Vico 60 - 36015 SCHIO (VI) ITALY
☎ +39 0445 502011 - Fax +39 0445 502010
internet: <http://www.fas.it> - e-mail: info@fas.it

The instructions, drawings, tables and everything else contained in this pamphlet are of a confidential nature and, for this reason, no information can be reproduced wholly or in part, nor communicated to third parties without the written approval of FAS.















REGULATION (EC) No. 852/2004 on the hygiene of foodstuffs

























Fas International declares that the models listed below, if used in line with the correct procedures as described in the corresponding user manuals, comply with the general and specific hygiene requirements of the Regulation No. 852/2004 OF THE EUROPEAN PARLIAMENT AND OF THE COUNCIL of 29 April 2004, Chapter III , paragraphs 1 and 2g.

WHOM TO CONTACT IN CASE OF DEFAULT

In most of the cases, many technical inconveniences can be solved with small interventions and therefore we advise to carefully read this booklet before calling the Assistance Service. In case of anomalies or bad functioning which are not solvable, the user can apply to the local agent.

CONTENTS

1	GENERAL	3
1.1	MACHINE ID	3
1.2	LAYOUT OF ADHESIVE STICKERS	4
1.3	GUIDE TO CONSULTATION	5
1.4	SAFETY DEVICES	6
2	USE OF THE VENDING MACHINE FOR THE SALE OF FOOD PRODUCTS	10
2.1	ESTIMATE OF THE IMPACT OF TEMPERATURE SETTINGS ON FOOD WASTE	10
3	TECHNICAL CHARACTERISTICS	11
4	DOOR COMPONENTS	17
5	INTERNAL COMPONENTS	18
6	TRANSPORT, HANDLING, STORAGE AND UNPACKING	19
6.1	TRANSPORTATION AND STORAGE 	19
6.2	UNPACKING 	19
6.3	INSTALLATION 	20
6.4	WARNING FOR INSTALLATION	21
6.5	CONNECTING THE PAYMENT SYSTEM	21
7	WARNING FOR SCRAPPING THE MACHINE	21
8	OPERATION ON THE MACHINE	22
8.1	PRODUCT LOADING PROCEDURE FOOD ZONE 	22
8.1.1	GUIDELINES FOR LOADING PRODUCTS 	22
8.2	SPACER FOR PRODUCTS ON FOOD ZONE	23
8.3	PRODUCT EXPELLER	23
8.4	VENDING A PRODUCT	23
9	FUNCTION/PROGRAMMING KEYBOARD 	24
9.1	 MACHINE PARAMETERS	26
9.1.1	 CONFIGURATION	27
9.1.2	 PHOTOCELLS	28
9.1.3	 REFRIGERATION UNIT	30
9.1.4	 PAYMENT SYSTEMS	31
9.1.5	 TIMER	35
9.1.6	 DRAWER DISPLAY	36
9.1.7	 MANAGING SELECTIONS	37
9.1.8	 CLONING	51

9.1.9		AUDIT	51
9.1.10		OUTPUT TEST	52
9.2		CONTROL PANEL	52
9.2.1		UPDATE INTERFACE TYPE.....	53
9.2.2		UPDATE CUSTOMISATION	54
9.2.3		UPDATE CONFIGURATION	55
9.2.4		UPDATE MULTIMEDIA	56
9.2.5		IDENTIFICATION PARAMETERS	57
9.3		SALES DATA.....	57
9.4		EXPORT EVA-DTS DATA.....	58
		UPDATE MAIN-BOARD	58
9.5		SALE TEST	59
9.6		SHOW PHOTO	59
10		ERROR CODE TABLE	60
11		ADJUSTMENTS.....	61
11.1		SPIRALS	61
11.2		PROCEDURE FOR REPLACING SPIRALS AND EXPELLER MOTOR GROUP	61
11.3		PROCEDURE FOR REMOVING THE DRAWERS  	62
11.4		MODIFYING THE TRAY NUMBER  	62
11.5		PROCEDURE FOR CHANGING THE TEMPERATURE MANAGEMENT SIDE-PANEL  	63
11.6		FITTINGS FOR FASTENING TRAY WIRING  	64
11.7		INSTRUCTIONS FOR CONVERTING THE TRAYS  	65
11.8		ACCESS TO THE ELECTRIC PANEL AND REFRIGERATION UNIT  	66
11.9		INSTRUCTIONS FOR REPLACING THE INTERNAL LIGHTING DEVICE	66
12		INSTRUCTIONS FOR CLEANING	67
12.1		IMPORTANT POINTS FOR CLEANING.....	67
12.2		INACTIVITY	67

1 GENERAL



This manual has been prepared for the most complete model: consequently, there may be extra descriptions or explanations that do not apply to your machine.

This documentation is an integral part of the machine and must accompany it when it changes hands or is moved throughout the company.

Before installing and using the vending machine, you must read and fully understand this manual as it provides information regarding safe installation, operation and maintenance of the unit.

This manual provides all the information needed by the personnel assigned to running and maintaining the machine so they can operate in full safety.

Contact the manufacturer for any information, spare parts or accessories you may need. Never perform any operations you are unsure of. This is strictly forbidden.

The manual or a copy thereof must be kept near the machine, on hand for the operator to consult; it must be kept in a place protected from heat, humidity and corrosive agents (oils, lubricants, corrosive products).

The manual must be consulted carefully so as to prevent damaging it; never remove any pages, replace or delete information or modify the content of the manual in any way.

Any revisions and pages illustrating the accessories form an integral part of this manual and should therefore be added to it.

To access the online spare parts area, enter the following address:

<https://ricambi.fas.it>

The User Manual contains the energy label. Bear in mind that the energy label must only be attached to the vending machine in the point of sale (i.e. in the place where cooling appliances with a direct sale function are on display for sale, hire or lease-for-sale).

Remember also that the data on the energy label will no longer be valid in the moment when the machine is transformed by third parties (for example with the assembly of additional devices).

Use the QR code at the top right of the label if you need to check the data; you will be connected to the Eprel European Product Database, where you can find the original documents containing the indicated data

1.1 MACHINE ID

The following pages of this booklet show the user how to identify the VENDING MACHINE. This information will be very important later on as it enables the manufacturer to provide technical information quickly and safely and to facilitate spare parts management.



You are therefore advised not to damage or remove the means of product identification.

The ID label is a plastic laminated data-plate showing the information that must be provided to the manufacturer when needed.

This label is the only one recognised by the manufacturer for product identification.

1.2 LAYOUT OF ADHESIVE STICKERS

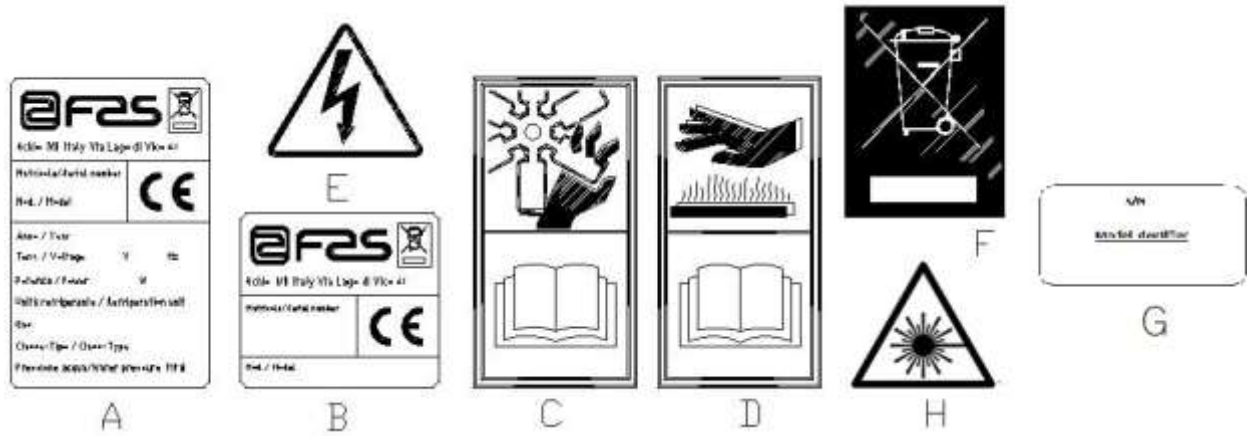





A	Full ID data-plate
B	ID label
C	Safety sticker indicating the danger of rotating parts
D	Safety sticker indicating surfaces at high temperatures
E	Safety sticker indicating the presence of electrical voltage
F	Disposal in compliance with EU 2002/96/CE standards, according to the implementation of the Directive into the national law.
G	Energy range identification plate
H	(LED LIGHTING) LASER RADIATION - DO NOT STARE INTO BEAM - CLASS 2 LASER PRODUCT

The complete ID label "A", showing all the machine information, is set inside the body (see diagram below). If there is printing on the side of the body, label "B" is placed on the back of the body, at the top right. Furthermore, the serial number is also printed on the most important element of the machine (fans, compressor cards, etc.).



1.3 GUIDE TO CONSULTATION



SYMBOL	MEANING	REMARKS
	DANGER	Indicates a danger that may even lead to death.
	WARNING	Indicates a warning or notes on key functions or useful information. Pay close attention to the text accompanying this symbol. It requires that maintenance personnel take a measurement reading, check a report, check the correct positioning of some part of the machinery, etc., before performing a certain command or operation.
	SCHEDULED MAINTENANCE ACTIVITIES	<i>The term scheduled maintenance indicates:</i> the reloading operations, setting the control parameters, emptying out the coins, and the cleaning operations in the areas in contact with the food products.
	SPECIAL MAINTENANCE ACTIVITIES	<i>The term special maintenance indicates:</i> maintenance tasks of varying complexity (mechanical, electrical, etc.), performed under particular conditions or agreed upon with the user and not considered under the scheduled maintenance activities.
	RECYCLING	The materials must be disposed of in an environmentally friendly manner. This is mandatory.

Pay close attention to any text in bold face, a larger font or underlined, as it always refers to operations or information of particular importance.

The attached wiring diagrams are to be used exclusively by skilled technicians authorised by the manufacturer to carry out maintenance and special controls.

On the pages that follow, when referring to the machine, the terms "front" or "forward" indicate door side, while the term "back" or "rear" is used to indicate the opposite side; the terms "right" and "left" refer to the operator's right and left side when standing in front of and facing the unit.

For each operation to be carried out on the machine, a level of expertise (see below) is given to indicate the persons qualified to perform the operation concerned.

Final user	Person without specific expertise, able to perform the operations of purchasing and retrieving the product only by using the controls displayed on the machine or by following the instructions given on the display
Scheduled maintenance operator	Persons able perform the tasks indicated for the previous qualification level and, in addition, to operate according to the instructions indicated with the symbol  in this manual
Special maintenance operator	Personnel able perform the tasks indicated for the previous qualification levels and, in addition, to operate according to the instructions indicated with the symbols   in this manual. In some cases, the skilled technicians must also be able to intervene with the guards disabled, and thus under unsafe conditions. However, operations with moving and/or powered parts must only be performed in exceptional cases and only when intervention under adequately safe conditions have proved impossible. Only persons with the knowledge and practical experience with the unit — in particular with unit safety and hygiene — should be allowed access to these areas.

The operations described in this manual — covering all phases of the machine life cycle — have been carefully analysed by the manufacturer. Therefore, the number of operators and their indicated qualifications are those most suitable to best perform the functions.

1.4 SAFETY DEVICES



This appliance can be used by children of at least 8 years of age and by people with reduced physical, sensory or mental capabilities, or insufficient experience and knowledge, provided that they are carefully supervised or instructed about how to use the appliance safely and the risks that this entails .



The use of non-original accessories or components endangers the safety of the machine. Manufacturer disclaims any and all liability if non-original spare parts or accessories are used and is not accountable for any damages, direct or indirect, that may arise from such improper use. The variety of similar products that may be made available on the market prevents manufacturer from checking them. Caution: the use of components and spare parts that are not original may void the entire machine warranty.



The vending machine construction and analysis relevant to safety issues refer to the requirements in force.

The power supply wire is of the type with non-separable plug. If the connection cable needs to be replaced, the work must only be performed by qualified assistance-service personnel.

Any work other than routine maintenance should be performed with the unit disconnected from the power supply.



Always wear suitable clothing, as indicated herein and in the current national laws in force in the country where the machine is to be used. This is mandatory. Never wear loose, fluttering clothing, belts, rings and necklaces. Long hair should be gathered up under a special cap.

Never operate the machine with the fixed and/or mobile guards disassembled or with safety devices bypassed. This is strictly forbidden.

Never remove or tamper with safety devices. This is strictly forbidden.

Never perform any maintenance or adjustments unless you have thoroughly read and understood the contents of this manual.

Adjustment operations performed with reduced safety or with the safety devices partially bypassed must be performed by a single person and access to the machine by unauthorised persons must be prohibited during this time. As far as possible, only one guard should be bypassed at a time.



After performing adjustments or maintenance under reduced safety conditions, always reinstate all guards and correct machine operating status as quickly as possible.

Diligent performance of the periodic, scheduled maintenance indicated herein is required both to ensure operating safety and to keep the machine in good working order.

Check that the safety labels are in good condition and study their meaning: they are required to prevent accidents. If they have deteriorated, been lost or refer to components that have been replaced, they must be replaced by requesting original replacement labels from the manufacturer and they must be set in the exactly the same position as shown in this manual



Remember: a prudent operator in good physical and mental condition is the best insurance against any injury.



Using the wiring diagrams to make modifications is strictly forbidden.



Using a different number of workers, or persons with qualifications below those required, could endanger the personnel involved or anyone in the vicinity of the machine.



Food products must be dispensed by the vending machine in hermetically sealed packages.
Comply rigidly with the producer's instructions regarding the expiry date of each product and the conservation temperature
The vending machine should be considered equipment suitable for maintaining the temperature of the products, **NOT** for cooling them.
For fresh and/or perishable food products, and in all cases provided for by the laws in force, it is necessary:
to set the internal temperature of the vending machine in accordance with the laws in force;
during transportation to the vending machine, to maintain the products at the temperatures provided for by the laws in force.









This vending machine is equipped with a "refrigeration safety device" in accordance with the standards relevant to the preservation of fresh food in force in various countries which permits these products to be maintained in the conditions specified in the manual as long as these products are introduced at the correct temperature for their preservation as set forth in these standards.
The non-observance of this regulation could activate the "refrigeration safety device".



To guarantee the correct operation of the vending machine, do not change the position of the drawers.



CAUTION:
The "T.A." (ambient temperature) version of the vending machine, without the refrigeration unit, **IS NOT** intended for the sale of foodstuffs.

	In the event of fire, do not direct jets of water against the machine as this could cause short-circuiting and result in accidents, even fatal, for persons nearby.
	Turn off the machine using the main switch and unplug it before starting any cleaning operations. Do not wash the vending machine with direct and/or high pressure water jets.
	Never immerse the coin mechanism in water Do not use abrasive materials Do not use spray lubricants
	Do not keep explosive substances such as aerosol cans with a flammable propellant in this appliance
	This appliance is intended for use in domestic and similar applications, such as: - kitchen areas for staff in shops, offices and other workplaces; - farm holiday centres and guests in hotels, motels and other residential venues; - bed & breakfast and similar venues; - catering and similar non-retail applications.
	The appliance must be connected to a power supply mains featuring earthing which complies with current legislation. The manufacturer recommends providing an electric power supply mains for the vending machine which is equipped with a disconnecting device having a contact opening of at least 3 mm. Leave the plug accessible after installation. Never use extension cords, adapters or trailing sockets.
	CAUTION: when positioning the appliance, make sure the power cord is not trapped or damaged

2 USE OF THE VENDING MACHINE FOR THE SALE OF FOOD PRODUCTS

	<p>CAUTION: To determine and set the conservation temperatures of the food products, comply with the instructions provided by the producer and by the relative laws in force. These operations must be assigned to adequately qualified personnel as defined by the person in charge of the equipment.</p>
---	---

The vending machine can be used for the sale of food products.

Some **examples** of food products that can be sold include:

- sweets, hazelnuts, chewing gum and similar sweets
- biscuits, crackers and similar oven-baked products
- foods with a pH level of 4.6 or less or with a water activity value (Aw) at 25°C of 0.85 or less
- foodstuffs maintained at a temperature of 5°C or lower for a period of time specified by the producer, but not more than 5 days
- foodstuffs packaged in hermetically sealed containers
- foodstuffs that have been treated to prevent deterioration

2.1 ESTIMATE OF THE IMPACT OF TEMPERATURE SETTINGS ON FOOD WASTE

	<p>CAUTION: The use of the correct programming parameters will allow the food products to be stored until their natural expiry date, thereby minimising waste. An accurate HACCP analysis is also recommended however, to avoid refrigeration safety device (Health Control) settings that are too strict for the real external temperature parameters; remember that, by law, all perishable products must be thrown away every time the safety device is activated.</p>
---	--

3 TECHNICAL CHARACTERISTICS

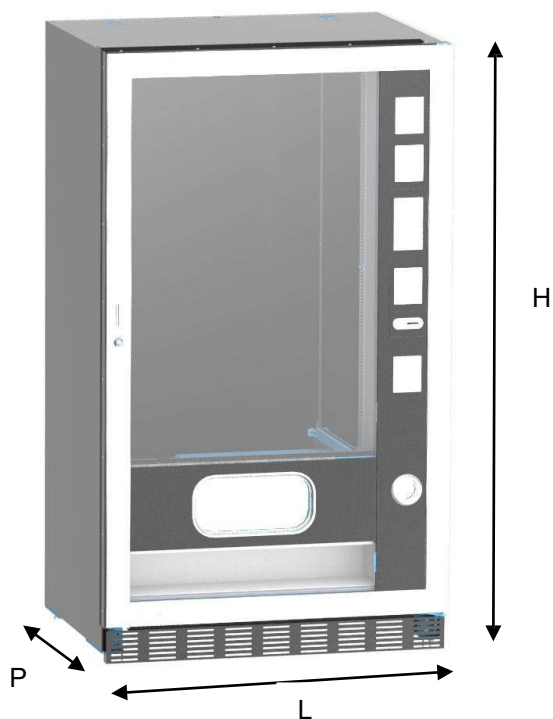

Height	H = 1830 mm H = 1700 mm (BUSINESS)
Width	L = 750 mm (750) L = 900 mm (900) L = 1050 mm (1050)
Depth	P = 790 mm
Weight (without packaging)	224 kg (BUSINESS) 239 kg (750) 270 kg (900) 340 kg (1050)
Rated voltage	see ID data-plate
Rated power	see ID data-plate
Limit environmental conditions for operations	Ambient temperature - max. 32°C Ambient temperature - min. 3°C Relative humidity - max. 65%
Refrigeration system	Compression - class N Cyclic defrosting
Vending system	FIFO
Delivery door	1
Max. weight per drawer	15 kg evenly distributed 30 kg evenly distributed (reinforced guides)
Weighted sound pressure level "A"	Less than 70 dB

SPIRALS FAS 1T

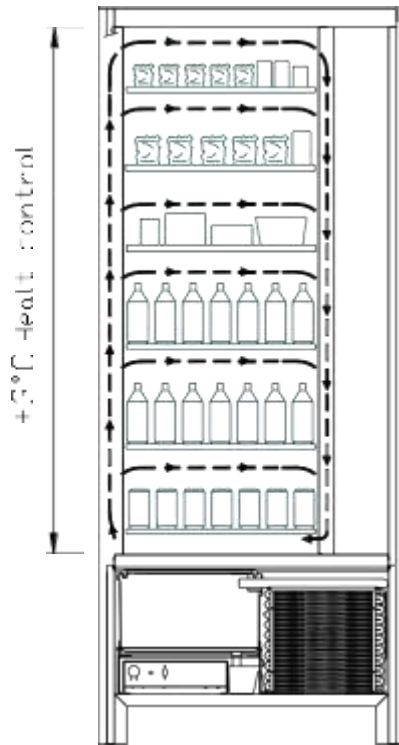

- All the drawers can be set at a temperature of +3°C to ensure the good preservation of foodstuffs which are perishable at higher temperatures. In this area, in accordance with the "HACCP" (hazard analysis and critical control points) standard, a control device, called "refrigeration unit safety device", prevents the sale of products if the temperature which can deteriorate the product is exceeded.

SPIRALS FAS 2T with an electronic system make it possible to have two areas with different temperatures, specifically:

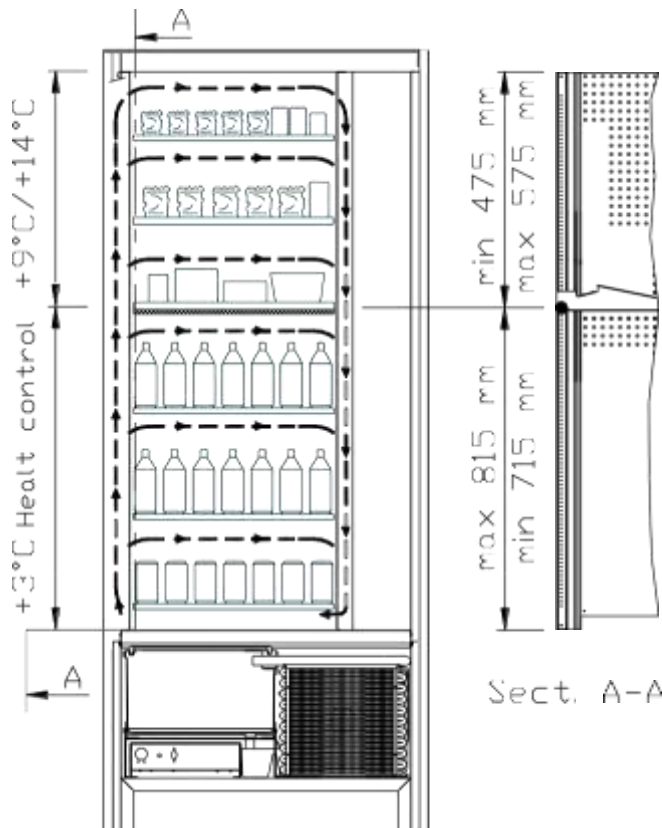

- **top drawer area** where the temperature is stratified from +9°C to +14°C; ideal for shelf-stable products.
- **bottom drawer area** where the temperature can be set at +3°C for a good preservation of perishable food substances which would not otherwise resist higher temperatures. In this area, in accordance with the "HACCP" (hazard analysis and critical control points) standard, a control device, called "refrigeration unit safety device", prevents the sale of products if the temperature which can deteriorate the product is exceeded.

The two areas are isolated from each other by an insulating panel.

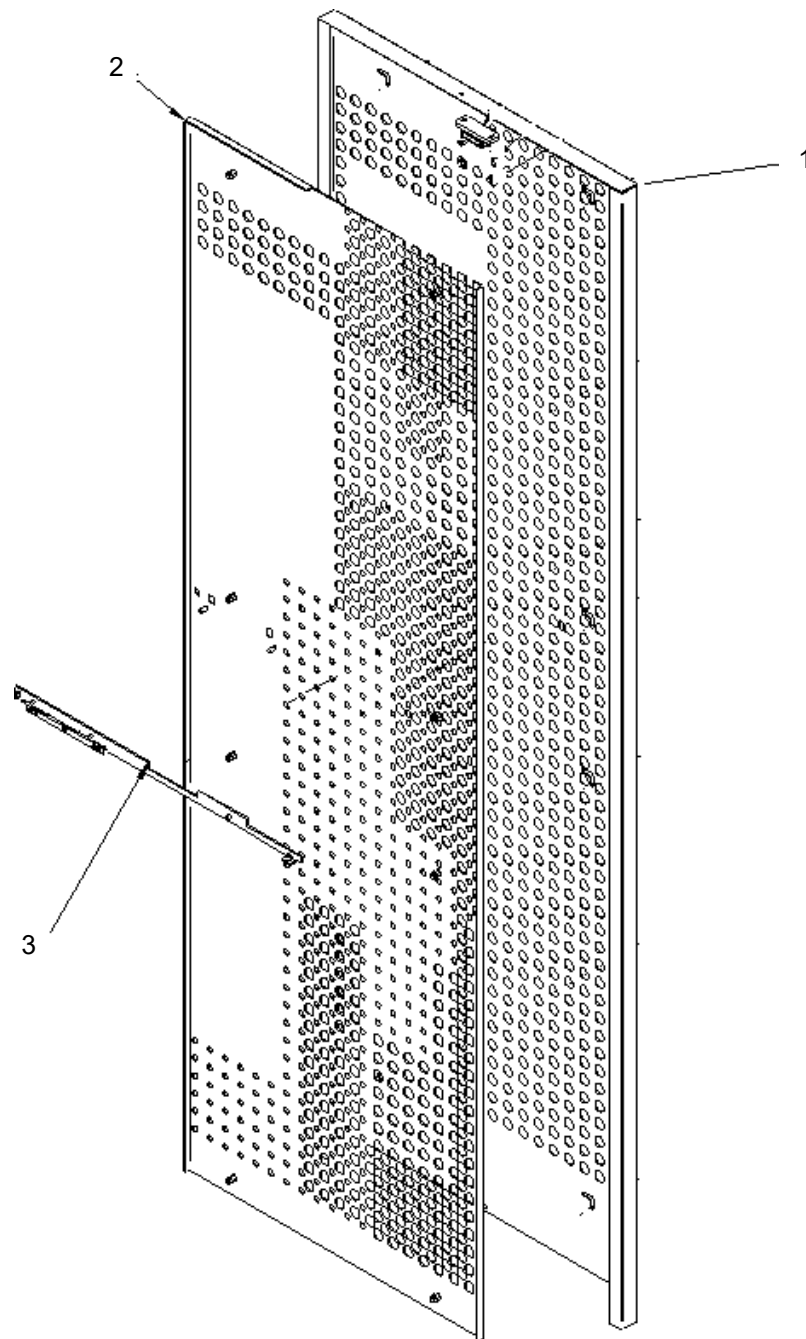

1. external fixed side panel
2. internal mobile side panel
3. mobile partition

1T configuration:

	<p>The position of the internal mobile side wall can be changed by loosening the 8 screws and moving the partition up or down the slots. Retighten the screws to hold it in place. 1T configuration is obtained by positioning the screws as shown alongside.</p>
	<p>In 1T configuration, the mobile partition in the internal mobile side wall must be positioned vertically (leaving the air flow completely free) and fixed from the front by inserting two screws in the points indicated</p>

2T configuration:

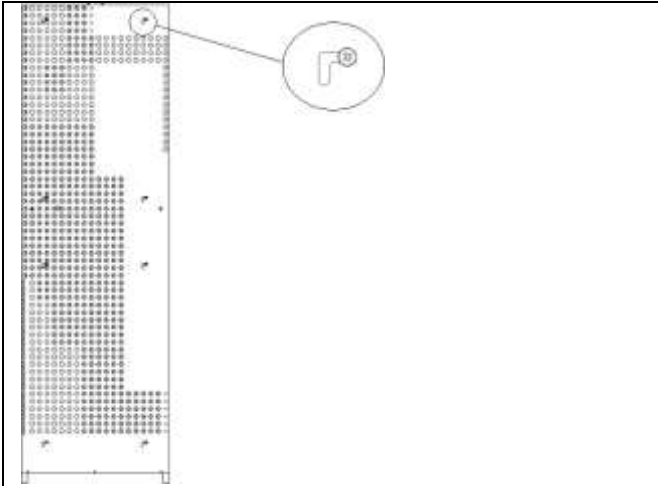

The position of the internal mobile side wall can be changed by loosening the 8 screws and moving the partition up or down the slots. Retighten the screws to hold it in place. 2T configuration is obtained by positioning the screws as shown alongside.

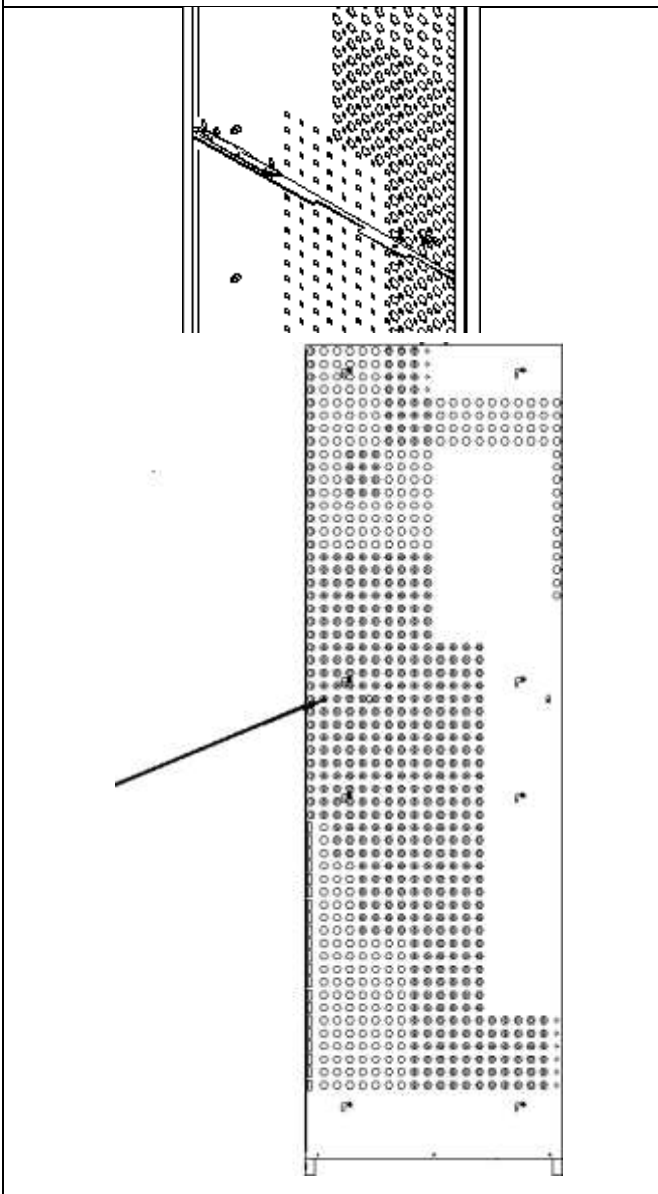

In 2T configuration, the mobile partition in the internal mobile side wall must be positioned horizontally (partly blocking the air flow) and fixed from the front by inserting a screw in the point indicated

SPIRALS FAS 3T (each product stored at the optimal temperature).

SPIRALS FAS 3T with an electronic system make it possible to have three areas with different temperatures, specifically:

- **top drawer area** where the temperature is approx. $+10^{\circ}\text{C}$, which is ideal for shelf-stable products.
- **middle drawer area** where the temperature can be set at $+3^{\circ}\text{C}$ for a good preservation of perishable food substances which would not otherwise resist higher temperatures. In this area, in accordance with the "HACCP" (hazard analysis and critical control points) standard, a control device, called "refrigeration unit safety device", prevents the sale of products if the temperature which can deteriorate the product is exceeded.
- **bottom drawer area** where the temperature is approx. $+6^{\circ}\text{C}$, which is ideal for beverages and/or shelf-stable products.

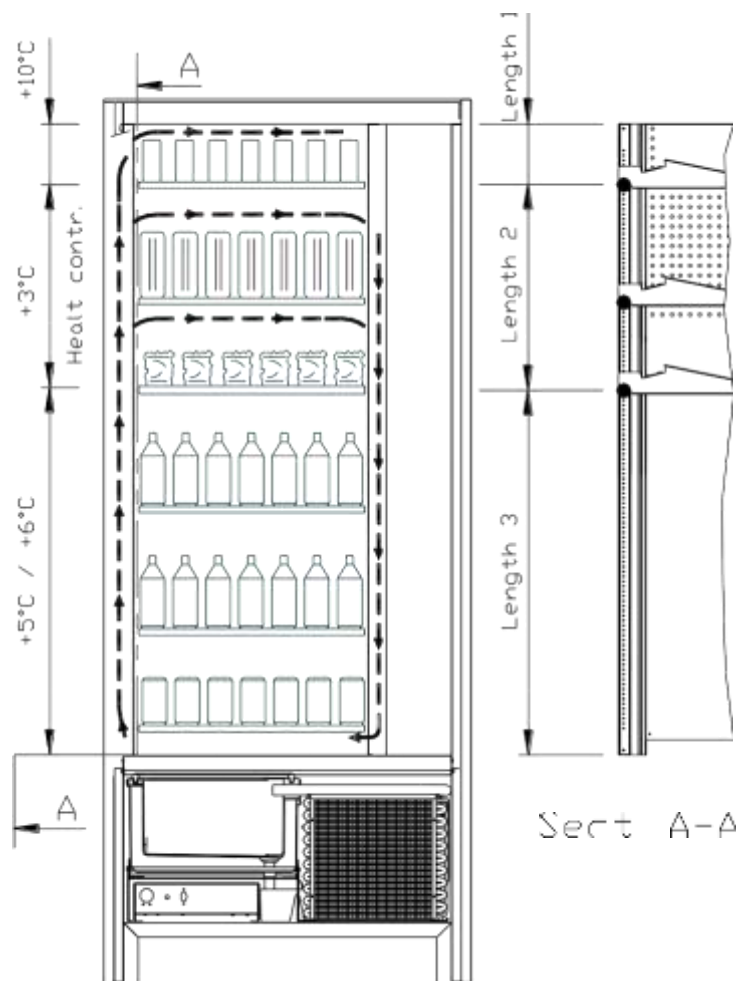

4 DOOR COMPONENTS

- 1 **Display:** The total of the coins inserted in the slot, the selection reference, the price of the selection and all the operating messages appear on the display. If there is a problem with the vending machine the number of the current alarm appears on the display.
- 2 **Coin return button:** this button is used to release any coins jammed in the coin mechanism and return them to the coin return cup.
- 3 **Coin slot:** the customer inserts the credit required to purchase the product in this slot.
- 4 **Delivery door:** the customer collects the product selected from this enclosure.
- 5 **Coin return cup:** located on the lower part of the machine and used to give change.
- 6 **Door lock.**
- 7 **Foot skirting board**

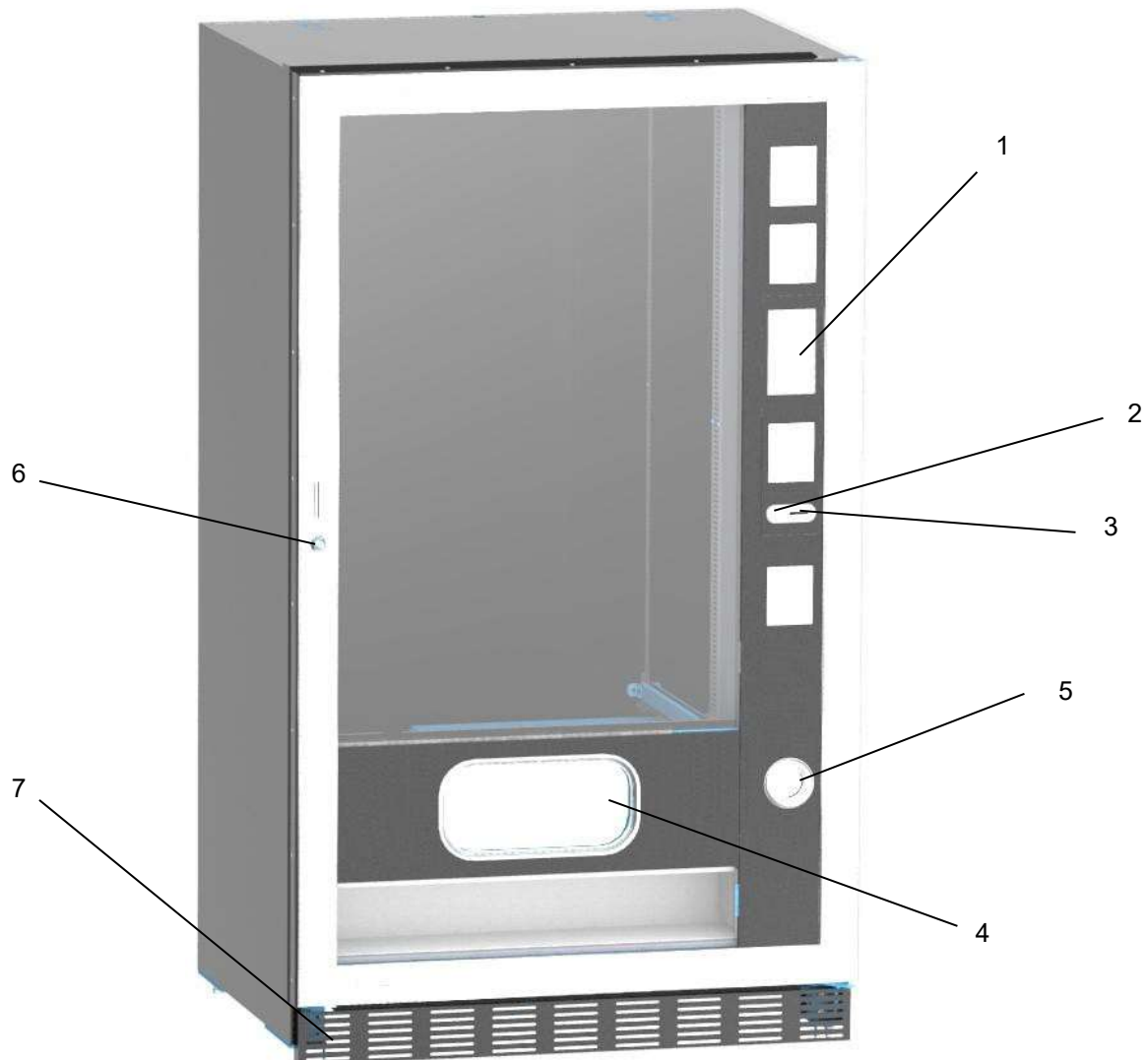

fig. 1

5 INTERNAL COMPONENTS

- 1 **Main board:** situated inside the coin mechanism box and manages the various functions of the vending machine.
- 2 **Refrigeration unit:** installed at the bottom of the cabinet, behind the collection pocket; it keeps the internal temperature of the vending machine at the set value.
- 3 **Electrical panel:** all the electrical connections, the power boards and the fuses are housed in the electric panel which is located in the lower part of the cabinet, behind the collection pocket.
- 4 **Door microswitch:** sends "door open" signal to the board
- 5 **Coin box**
- 6 **DRAWER DISPLAY BAR:** a back-lit bar which clearly shows the price and selection number in correspondence with the product. (if present)

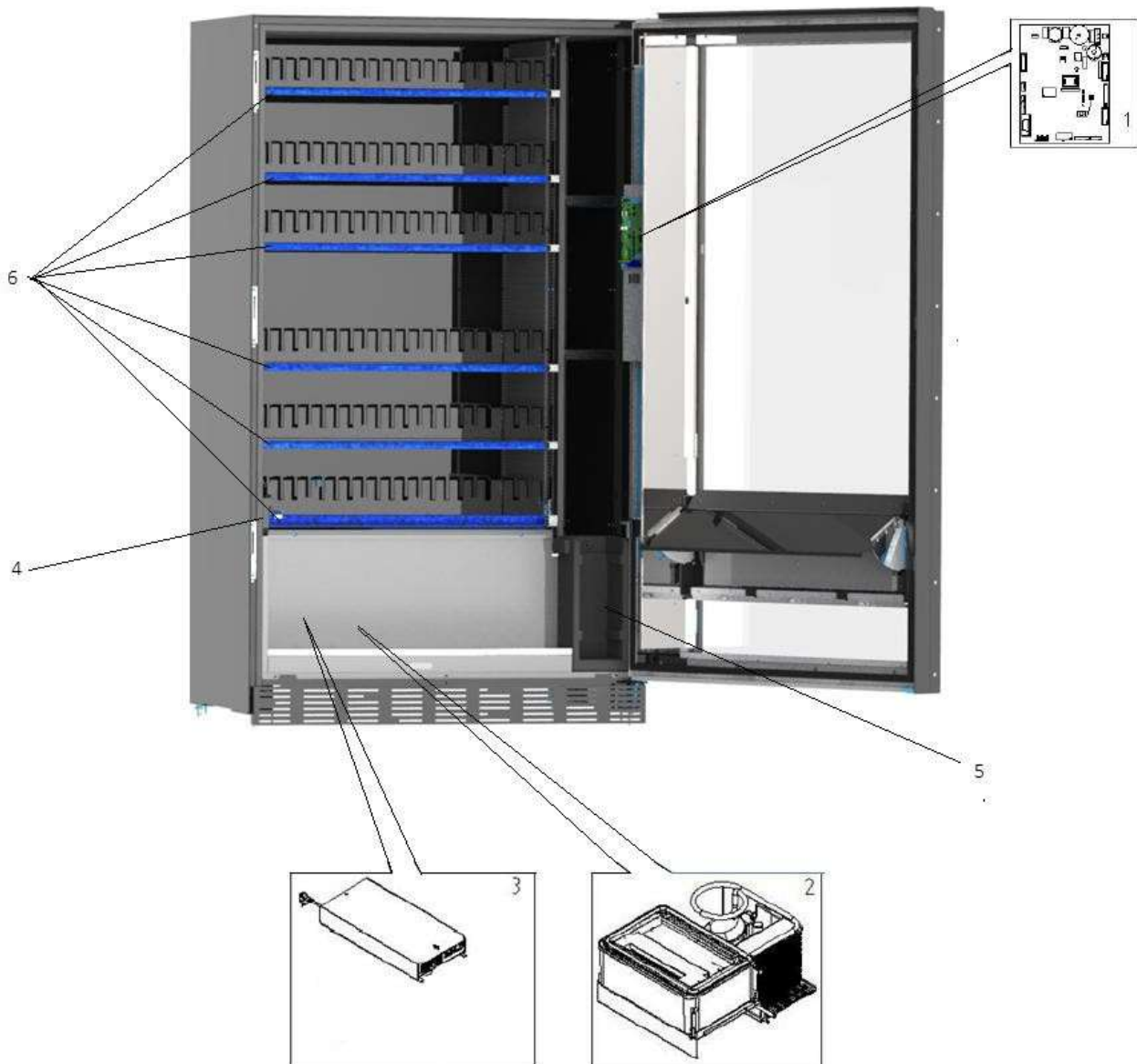

fig. 2

6 TRANSPORT, HANDLING, STORAGE AND UNPACKING



Examine the machine both inside and outside and notify the carrier immediately of any damage.

6.1 TRANSPORTATION AND STORAGE

In order not to cause damage to the distributor, the loading and unloading manoeuvring must be performed with particular care.

The loading/unloading manoeuvres must be carried out by lifting the machine with a lifting truck, either motor-driven or manual, and by positioning the forks in the area under the pallet.

To move the machine over short distances, for example inside a premises or office, the pallet need not be used. Proceed however with maximum caution to prevent damaging the machine. Instead, the following are always strictly **forbidden**:

- To lay the machine down;
- To drag the distributor with ropes or similar;
- To lift the distributor from the sides;
- To lift the distributor with any type of sling or rope;
- To shake the distributor and its packaging.



It is strongly advisable never to lay the vending machine on its side so as to ensure that the oil in the compressor does not leak from its seat. If it does, it would no longer be possible to guarantee the correct lubrication of the compressor itself and could lead to breakdown when starting up. If the vending machine is laid flat, place it in an environment with a temperature no less than 18°C and wait at least 2 hours before operating the machine again.

As to the storage of the machines, it is appropriate that the environment of conservation is very dry with temperatures between 0° and +40°C.

After having set the machine in a protected environment, cover it and avoid accidentally moving or bumping it. **Never** stack several packaged machines on top of one another, and keep in the vertical position as indicated by the arrows on the packaging itself.

6.2 UNPACKING

The packing material must be removed carefully to avoid damaging the machine. Inspect inside and outside the cabinet for any damage. Do not destroy the packing materials until the carrier's representative has examined them.



Remember to remove packing materials or equipment inside the vending machine which could affect the correct function of the machine.

To remove the machine from the pallet, simply loosen the 4 hexagonal-head screws (2 at the back of the distributor and 2 at the front) which secure the machine base to the pallet and which are reached by opening the door.

To ensure the correct circulation of air in the refrigeration unit, re-install the rear brackets which secure the vending machine to the pallet, upside down.



Always dispose of packing materials in an environmentally-friendly manner and in compliance with current law.



When lifting the vending machine, ensure that the supporting feet are removed from the pallet.

6.3 INSTALLATION

The vending machine must be installed in a place (floor, intermediate floor) that is - or can be - aired, and that can withstand its weight.

	The unit cannot be installed outdoors, must not be exposed to direct sunlight or installed where jets of water may be used. The unit can be installed in a place with ambient temperature ranging between 3°C and 32°C.
---	---

Check that the power of the whole electrical system is adequate for the maximum power of the machine (see plate). When in doubt, contact a qualified technician. Such personnel should also verify that the section of the plant cables are suitable for the power absorbed by the vending machine.

	<p style="text-align: center;">The following guidelines apply only to the United Kingdom.</p> <p style="text-align: center;">The cables are colour coded as follows: GREEN AND YELLOW - EARTH ---- BLUE - NEUTRAL ---- BROWN - PHASE</p> <p>As the colours of the wires in the unit cable may not correspond to the coloured markings on the terminals in your plug, proceed as follows: Connect the GREEN and YELLOW wire to the terminal which is marked E, bears the earth symbol, or is coloured either GREEN or GREEN and YELLOW. Connect the BLUE wire to the terminal which is marked N or is coloured BLACK or BLUE. Connect the BROWN wire to the terminal which is marked L or is coloured RED or BROWN.</p>
---	--

	The manufacturer cannot be held responsible for damages caused by the failure to observe the precautions given above.
---	--

- Once the connections have been made, the vending machine must be placed near a wall so that its back has a minimum distance of 7 cm from the wall in order to allow for regular ventilation.
- After having positioned the machine, adjust the four adjustable feet so that the machine is perfectly horizontal; all the feet should touch the floor.
- Mount the front leg cover.
- Check both the front leg cover and the mesh screens behind and under the refrigeration unit to ensure that they are always clean and not blocked in any way.

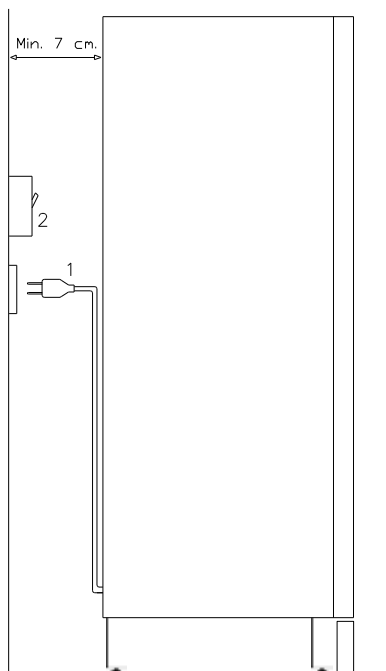

Description of connections:

- 1 "Schuko" German-type plug
- 2 Differential magneto thermal switch

- To switch on the machine, follow the instructions below. To connect the wiring cable. If the message "MEMORY CLEARED" appears on the display, press the button on the main board inside the box of the coin dispensing mechanism to initialise the memory. The message "DOOR OPEN" appears on the display. The vending machine will automatically start a self-test. If no errors are identified, the machine is ready to use.
- Program the machine (see the "PROGRAMMING" section), set the REFRIGERATION PARAMETERS (see the relevant paragraph) in accordance with the food products loaded into the automatic vending machine and set the prices.
- If the machine is supplied with a change-giving mechanism, insert the corresponding coins in the change-giving tubes.
- Load the machine with products (see the "Loading the products" section).

6.4 WARNING FOR INSTALLATION

The machine is sold without a payment system. Therefore any damage to the machine or harm to people or property due to the incorrect installation of the payment system will be the exclusive responsibility of those who made the installation.

6.5 CONNECTING THE PAYMENT SYSTEM

The coin mechanism must be connected and disconnected with the machine switched off.

The connectors required to connect the coin mechanism are located next to the main board. The vending machine is set up for payment systems with EXECUTIVE, MDB and BDV protocols.

- Fasten the coin mechanism on the support between the two pins.
- Connect the coin mechanism connectors to the machine.
- Adjust the coin chute on the coin mechanism opening
- Adjust the coin return button leverage

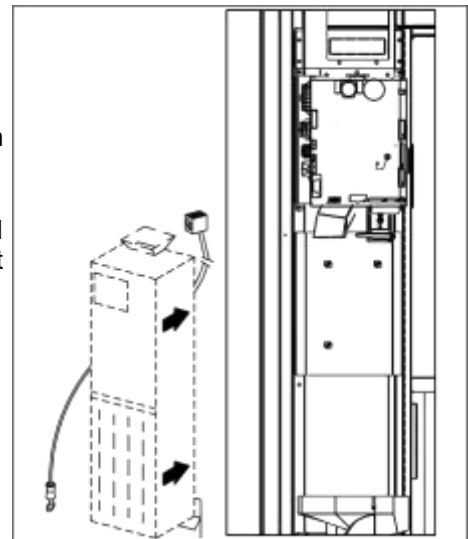

7 WARNING FOR SCRAPPING THE MACHINE

If the machine is disassembled in order to be definitively demolished, it is obligatory to follow the rules in force regarding the protection of the environment. All ferrous, plastic or similar materials should be taken to the authorised depots. Particular attention must be made to:



The **gases** in the refrigeration unit (of any type - refer to the identification plate) must be collected with suitable equipment by specialised firms
The **insulation materials** must be recovered by specialised firms.

If you have any queries, you are recommended to contact the relevant local refuse disposal authorities.

8 OPERATION ON THE MACHINE

8.1 PRODUCT LOADING PROCEDURE FOOD ZONE

Once the machine has been installed and programmed, proceed as follows:

- 1) Open the door.
- 2) Pull out one drawer at a time, by holding it on the bottom and pulling outwards until you reach the stop point. The drawer will tilt downwards to facilitate loading.
- 3) Start the loading from front to rear and make sure all the spaces are loaded. The bottom of the product should be placed on the base of the division right above the spiral, with the label turned to the window so that it is recognisable by the customer. All products have to be easily placed in the spirals; do not introduce bigger objects. Spirals can have different pitches and therefore you should choose the spiral suitable for the product you want to vend, or vice-versa choose the product according to the spirals you have.
- 4) After having loaded all drawers, make sure they return to the "STANDBY" position. Each spiral can be rotated by 45° at a time. Most of the products can be sold without trouble when the spiral end is positioned at 6 o'clock. For brik products, adjust the end 90° in advance.

NOTE: Products in bags or boxes must be correctly placed. The sealed edge of the bag may slip under the spiral wire, preventing the bag from falling. It is recommended to fold the edge forward and upward before inserting the bag in the space of the spiral. Products like cakes, biscuits, "handle with care" objects, etc. should be placed in the lower drawers so they won't be damaged when they fall.

8.1.1 GUIDELINES FOR LOADING PRODUCTS

Check the TECHNICAL CHARACTERISTICS chapter to identify which configuration your automatic vending machine corresponds to, in order to identify the exact area controlled by the "refrigeration unit safety device". When the machine is switched on for the first time, wait approximately 12 hours for the machine to reach the operating temperature. In any case, check that the internal part of the machine has dropped below 4°C before inserting the refrigerated products.

If the "refrigeration unit safety device" has tripped, the products in the selections that are out of order must be eliminated; also in this case, when the machine is switched back on again, wait for the machine to reach the operating temperature before placing the new refrigerated products inside it.

To remain within the safety limits for the refrigerated products, the total door-open time must be no more than 15 minutes. Consequently, all operations must be carried out as quickly as possible.

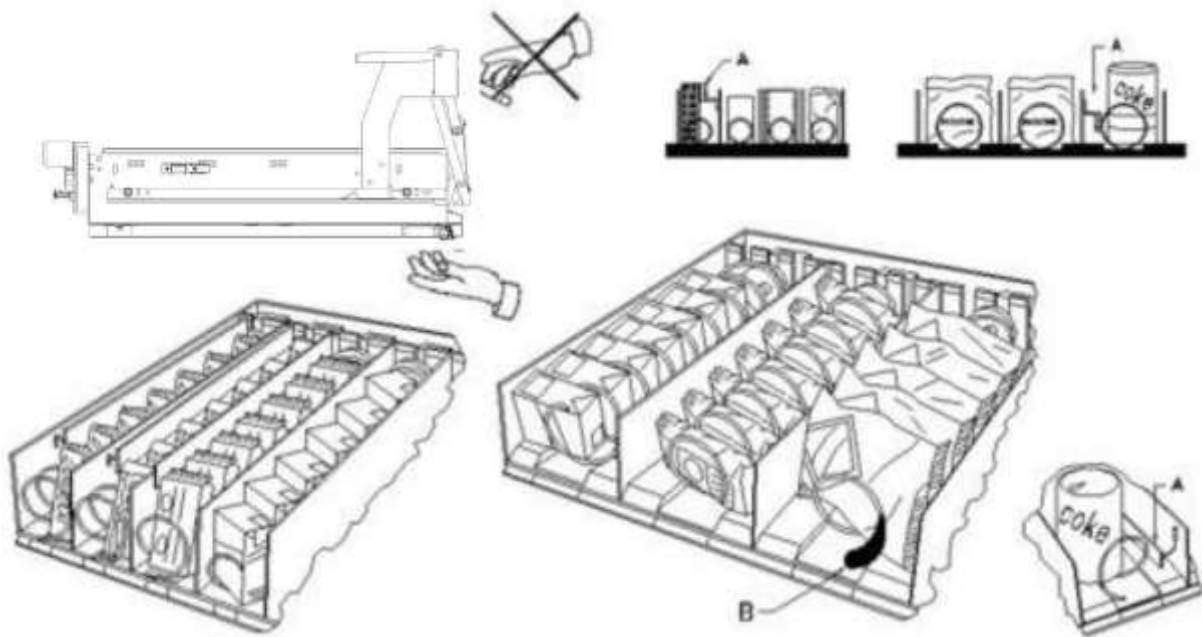

fig. 3

8.2 SPACER FOR PRODUCTS ON FOOD ZONE (fig. 3)

Spacers -A- should be used when "narrow" products are loaded.

Place them so that they push the product freely against the right side of the division and the product stands straight.

To settle the spacer, pull forwards to narrow the space, pull backwards to widen the space. Leave 3 mm between spacer and product.

8.3 PRODUCT EXPELLER (fig. 3)

The expeller -B- can be used when there are products in packets, like crisps etc. The expeller will help them come out of the spiral. It is hooked up at the end of the spiral and acts as an additional part of the product to vend pushing it out of the drawer.

8.4 VENDING A PRODUCT

After loading the machine, setting the selling prices for each product, positioning the price labels, checking that the drawers have been turned in selling position, the machine is ready to vend.

- 1) Insert enough money to buy the product.
- 2) On the panel, enter the combination corresponding to the chosen product.
- 3) Take the product from the delivery door.













9 FUNCTION/PROGRAMMING KEYBOARD

Above the coin mechanism door, there are two buttons with the following functions:

1. Programming button
2. Do not use













Programming button: on entering programming mode, the following screen appears:

	Quit programming mode
	Display all firmware and software versions.
	Select the language for the descriptions in the programming menu and machine configuration
	Enter the sub-menu to set various machine parameters
	Cancel blocking and active errors
	Display and cancel error chronology
	Enter the sub-menu to set the logic interface, multimedia files and engine updates
	View sales data
	Export EVA-DTS data
	Reset the machine
	Update main-board software
	Access to sales test and display current and operative selections
	Allows you to view the photo of the machine configuration previously uploaded using the telemetry site



9.1 MACHINE PARAMETERS

	Quit and return to previous screen
	Set currency and discount mode. Set LED switch-off on opening the door and reduce standby brightness; display stroke counter and enable oven column management.
	Configure the photocells
	Set all parameters relating to refrigeration unit operation
	Access to the payment system programming sub-menu
	Set the weekly timer
	Configure the drawer displays
	Enter the sub-menu for selection management: prices, photocells, messages, inhibits.
	Import and export machine configuration
	Allows you to download EVA-DTS data by communicating with external systems (IRDA, etc.)
	Used to activate certain outputs in order to check their functionality: compressor, ventilation, lighting, etc.



9.1.1 CONFIGURATION

Currency: used to write the required currency (the parameter with precedence in any case is the currency symbol underneath the **Identification Parameters**)

Discount mode: the following discount types are possible depending on the option chosen in the drop-down menu:

- no discount.
- discount in certain time slots.
- discount on purchases with key/credit card (only possible in MDB mode).
- discount for time slots and purchases with key /credit card (only possible in MDB mode).



N.B. To apply discount by time slots, the time slots required in the weekly timer must be defined.

For machines with the cashless system, this command makes it possible to apply different price tables. The selection of the table to be applied at the time of sale occurs automatically via the communication protocol between machine and reader (only possible for MDB cashless systems which are provided with this option).

Buzzer enable: tick the box to enable operation of the buzzer during machine operation.

Reduce standby lighting: tick this box to reduce brightness during energy-saving slots (see Weekly Timer



sub-menu). If this option is disabled, the LEDs are completely switched off.

Switch off lighting when door is open: enable/disable the LED off with door open option.

Pocket lighting always ON: it is then possible to set the lighting of the collection drawer to always on or always off when no products are being distributed.

The system then asks you to set the **drawer illumination time**, i.e. the period in which the collection point LEDs flash after the product has dropped. Setting range: 5 sec. to 90 sec. - default 30 sec.

Enable internal temperature and evaporator temperature display: by ticking this box, both the internal temperature of the vending machine and the evaporator temperature will appear on the main screen in the STANDBY status.

Microwave module management enable: enable/disable microwave oven column operation.

Enable slave: this command enables the master/slave connection. It is possible to connect one slave snack



machine. Once the box has been ticked in the main menu screen, the **Slave programming** icon will appear which allows access to the various settings of the slave machine connected.

If there is a slave vending machine, it must be connected to the master in order to work properly: in fact the operating parameters can only be set via the commands of the master machine. In particular, the temperature for the storage of perishable products is only guaranteed if the slave machine is connected to a master machine, set with the correct programming parameters



9.1.2 PHOTOCELLS

This screen is used to enable photocells by ticking the appropriate box. This flag should only be included if the system is equipped with photocells.



If the box is flagged (photocells enabled), it will be possible to switch on, through the **Photocells**



icon under the **Selection Management** menu any inhibition of this function for the desired selections (delivery without photocell control).

Hysteresis: this parameter acts on the sensitivity of the reading of the system. The lower the value set in this parameter, the greater the sensitivity of the system. The value can vary from a minimum of 5 to a maximum of 30.

Options: the selection made in this drop-down menu determines how the machine will react if the product is not delivered.

Possible settings are as follows:

- **Select another product:** possibility to make another selection. In this case, the machine must be set to multi-sale (for an executive protocol payment system, multi-sale must also be set in the payment



system). To set multi-sale mode for the machine, use the **Type** icon located in the **Payment systems** sub-menu to access.

- **Automatic credit delivery:** in this case, the machine must be set to single-sale (for an executive protocol payment system, single-sale must also be set in the payment system).
- **Quarter turn:** if the product is not delivered, the spiral completes a further 1/4 turn and if the product has still not been delivered then the machine reverts to one of the preceding two options depending on the single or multi-sale parameter that has been set.
 - *For this purpose, once this mode has been set, the option is disabled by default for all selections.*



In order to enable the single spiral option, select the **Selection management** icon and



then the **Photocells** icon. *The option is not applicable to 1/2 turn spirals. If the payment system uses an Executive protocol, the single/multi-sale must also be set in the payment system. Alternatively, it is possible to enable/disable the function for each drawer or directly for all selections.*

- **Multi-step** (multiple partial rotations): if the product is not delivered, the spiral will execute a further 1/8 turn and this will be repeated 4 times if the product is not delivered; on the fifth attempt, the spiral will complete the turn and a product delivery check will be performed, after which one of the options **Select another product** or **Automatic credit delivery** will be triggered depending on whether the single or multi-sale parameter has been set. Also in this case, the function must be enabled for each selection, drawer or total (see previous point).

The system then makes it possible to set the "empty" option which, if enabled, blocks the selection until the next opening of the main door, in the event of failure to deliver the product.

The system then asks you to enter the options relevant to the PHOTOCCELL SAFETY:

enabling this feature involves entering a number of products within a time window (in minutes). If within the programmed time interval a number of non-readings occurs that is equal to the number of programmed products, the photocells are disabled. The active event is signalled on the display when the door is opened



and is also recorded under Error code 39. The photocell reset can be programmed in manual mode or automatically by ticking the **Auto-reset** box. In automatic mode (box ticked), after 15 minutes the system attempts to reset the function.



Calibration: this command is used to test that the photocells are functioning correctly.

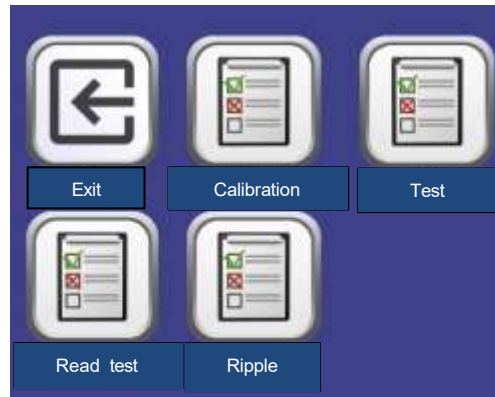

When the type of test to run has been selected, a test procedure is started automatically; the result is displayed on completion.. If there is a problem with the functioning, a second value appears on the display which refers to the problem.

Calibration: starts the photocell calibration procedure by optimising the light emitted by the photo-diodes

Test: verifies calibration

Read test: performs a physical read test

Ripple: this procedure provides the difference between maximum and minimum emitted light readings. This value must be less than the hysteresis value

N.B.: With SPIRALS SLAVE connection enabled (see “Slave enable” below the menu



General

Enables), you can access the same parameters for the SLAVE machine using the programming icon that appears in the main menu



Slave



9.1.3 REFRIGERATION UNIT

Internal temperature: sets the lower internal cabinet temperature of the machine, i.e. the temperature below which the compressor is turned off. The pre-set value is +3°C. This value can be varied between +2 and +25°C.

Defrost termination temperature: every time the compressor pauses, the temperature of the evaporator is controlled by the evaporator feeler. This command allows the evaporator temperature to be set, above which, after dripping, the compressor can restart operating; this is to ensure complete defrosting of the evaporator itself. The command is pre-set at 3°C and can vary between 3°C and 12°C.

Defrost interval: set the defrost interval in hours - i.e. the time between one defrost cycle and the next. This value can be varied from 1h to 8h, and is pre-set at 4h.

Refrigerator safety action delay: sets the delay time for refrigerator safety activation. This period of time prevents the vending machine from shutting down following an operation that involves having the door open with the subsequent increase in the internal temperature. The delay in activating the refrigeration unit safety device gives the machine time to return to its normal operating temperature. The value of this command is pre-set at 60 min, but can be varied from 30 to 360 min.

Refrigerator safety temperature: sets the trigger temperature for the safety device, that is the temperature above which it prevents the machine from vending the selected product. This control is disabled when the machine is switched on and after the door is shut for the period of time set in **Refrigerator safety action delay**. The pre-set value is +7°C, but it can be varied from +7°C to +35°C. When the refrigeration unit safety device trips, the selections involved remain out of service. To reset the refrigeration unit safety device: with



the door open, access programming mode and reset the error using the **Cancel errors** icon



Products must be inserted at the correct temperature for preservation as specified by the regulations in force. The non-observance of this regulation could activate the "refrigeration safety device".
see paragraph "GUIDELINES FOR LOADING PRODUCTS"

N.B.: With SPIRALS SLAVE connection enabled (see "Slave enable" below the menu



General

Enables), you can access the same parameters for the SLAVE machine using the programming icon that appears in the main menu



Slave



9.1.4 PAYMENT SYSTEMS



9.1.4.1 TYPE

Payment system: it is possible to choose the type and mode of coin mechanism operation. The parameter can assume the following values:

- EXECUTIVE with prices managed in the machine
- EXECUTIVE PRICE HOLDING (i.e. prices programmed in the coin mechanism); in this case, prices



programmed using the **Prices** icon must be the same as those programmed in the coin mechanism. Alternatively you can set the “Price-Display” parameter. If enabled, the machine will exclusively use the price information received from the payment system

- BDV
- MDB

Single/multi-sale: it is possible to choose whether the vending machine operates in single-sale mode and thereby gives change in cash mode. If this is not possible, the sum is added to the amount totalled due to overpricing. Conversely, if the vending machine operates in multi-sale mode, the amount in excess of cost after the sale is displayed once again and can be recovered by simply pressing the “change” button or used for a new selection.

Setting the signal for payment system out of order: it is possible to choose whether to block the vending machine if the payment system is out of service.

Enable change-giver engine: enables the change-giver motor.

Coin insertion microswitch:

it is possible to enable the presence of the microswitch involved in coin insertion.

Change-giver motor cycle interval: sets the time interval between one change-giver motor cycle and the next during vending machine idle time. The single cycle is programmable between a minimum time of 2 minutes and a maximum of 250 minutes.



9.1.4.2 SETTINGS

EXECUTIVE:

Maximum credit: it is possible to set the maximum credit accepted by the coin mechanism. If this value is exceeded, acceptance of further coins is blocked

EXECUTIVE PRICE-HOLDING:

Maximum credit: it is possible to set the maximum credit accepted by the coin mechanism. If this value is exceeded, acceptance of further coins is blocked

The **Price-display** function can be enabled/disabled. When enabled, the machine will exclusively use the price information indicated by the payment system

Enable pre-selection: tick this box to activate the mode that allows the selection to be made first and then the payment.

Pre selection time-out: after enabling the "pre-selection" mode, it is possible to set the maximum time in seconds that can elapse between selection and payment

After making sure that the payment system used supports the price table read function and that this function is enabled, it is possible to set the number of price lines used in the **Price Table Dimension** bar.

If the payment system also manages the cashless table, tick the **Read cashless prices** box.

After setting the dimension and the table and enabling, if necessary, reading the cashless prices, it will be

possible to read prices from the payment system by selecting the  **Read prices** icon

If the system does not support this function, compile the price table using the  **Price table** icon.

BDV

Maximum credit: it is possible to set the maximum credit accepted by the coin mechanism. If this value is exceeded, acceptance of further coins is blocked

Maximum change: This function is active only in multi-sale. If the value of the remaining credit after a sale is greater than the value set in this line, giving change will be blocked. Therefore it will be necessary to make further purchases until the remaining credit is lower than the set value. By moving the return lever, it will be possible to obtain the change.

The Price-display function can be enabled/disabled. When enabled, the machine will exclusively use the price information indicated by the payment system

Level of coins for exact amount: a value between 0 and 15 representing the number of coins to be added to the minimum level fixed in the coin return tubes - can be programmed, in order to quit the "exact amount" condition.

Exact amount equation:

it represents the combination of empty spaces in the tubes so that the exact amount message can be activated. Here is a list of possible combinations:

0 = A or (B and C)	1 = A and B and C	2 = only A and B
3 = A and (B or C)	4 = only A	5 = only A or B
6 = A or B or C	7 = only A and C	8 = only A or C
9 = only B and C	10 = only B	11 = only B or C
12 = only C		

Enabling credit card reader: it is possible to tick the box and enable the credit card function



The icon **Inhibit coins** can be used to block acceptance of particular coins by the coin mechanism



The icon **Inhibit exact amount coins** is used to block acceptance of certain coins when very little change is due, i.e. when the display shows the message "Insert exact amount only".

MDB

Maximum cash credit: it is possible to set the max credit accepted by the coin mechanism by either key/card or cash is set, and if this amount is exceeded acceptance of further coins or banknotes is blocked

Maximum cashless credit: it is possible to set the maximum credit accepted by the coin mechanism for key/card purchases

Maximum change: the maximum quantity of coins that can be returned; default value 1000, max value 9000.

Maintaining overpay: ticking this box enables the option to maintain overpay at the user's disposal for an indefinite period of time

Purchase obligation before change is given: when this box is ticked, the customer is obliged to complete the purchase before receiving change. This is to prevent the coin mechanism being used as a coin-changer. If the purchase fails to happen, the change will be given out.

Minimum level of tubes: this is the number of coins for each coin box mechanism which must remain in each tube in order to guarantee the correct function of the coin delivery system (consult the manual of the coin box mechanism for instructions on setting the correct value of this parameter). If a different value is associated to each tube, the maximum value set must be between those indicated. The setting of this parameter is fundamental for ensuring the correct coin management by the vending machine.



N.B. The inventory of the tubes, icon  located in **Tube filling**, stops when the contents of each tube reaches the value set at **Minimum tube level**. To empty the tubes completely, use the coin box mechanism delivery buttons.

Enable acceptance of banknotes in exact amount condition: ticking this box under exact amount conditions inhibits the banknote reader.

Update content of change-giver tubes from coin mechanism: select whether to use the counters corresponding to the content of the coin mechanism change-giving tube or use only the counters inside the machine. When the box is ticked, at each power-up the counters inside the machine which correspond to the content of the change-giving tubes are updated with the values transmitted by the coin mechanism.

Inhibit cashless credit display: prevent or enable display of credit from the MDB cashless device (key or card reader). When the box is ticked, the credit for the cashless device is not displayed



Level of coins for exact amount: this command is for setting (for each change-giving tube) the number of coins below which the machine can be considered to be in a condition of 'no coins available for change'. The set value must always be higher than the minimum coin level in the tubes (example: if the **Minimum level of tubes** is set at 5, the values set in this command must have a minimum value of 6). The tubes that are not included in this condition must be set at "0".

When the contents of any one of the tubes included in the condition drops below the corresponding set value, the machine displays the warning that there are no coins available for change.



Enable coins: enable/disable acceptance of particular coins by the coin mechanism.



Enable notes: enable/disable acceptance of particular banknotes by the reader



Enable exact sun coins: this command is used to enable/disable the acceptance of special coins in terms of rest small when the display shows the message "insert only exact amount".



Enable escrow: enable the "Escrow" function for each banknote



Coin table: it is possible to create a table by associating the value of coins and coin identification numbers when there is a selector instead of a coin mechanism. (i.e. associate a 1 Euro coin with Coin 3 and a 50 cents coin with Coin 4)



Filling tubes

On inserting coins into the tubes, the relative bar chart (T1 = Tube 1) is updated to show the number of coins inserted on top.



To empty a tube, click on the icon of the tube in question.



9.1.5 **TIMER**

The weekly timer settings sub-menu is accessed, which has the following options:

1. Energy saving
2. Time band discounts
3. Prevent selections

The first timer manages the "Power saving" option. If this option is enabled, since it is a weekly timer the user is prompted to choose the day from the drop-down menu; it is then possible to set 3 daily periods when this function is enabled/inhibited.

The second timer manages "Time band discounts". If this option is enabled, the sequence described in the previous paragraph is repeated.

The third timer manages "Disable Selections". If this option is enabled, the sequence described in the previous points is repeated.



The inhibition is then set for the entire machine or only partially, using the specific **Disable selection** function



9.1.6 DRAWER DISPLAY



After enabling the presence of the drawer display, select the icon **Read configuration**.



Next, tap on the icon **Assign address** and select "skip" for all drawers; the vending machine will automatically show the correct selection numbers



Configure type of drawer: in this case, the system makes it possible to configure each drawer: select the icon matching the number of the drawer and select the type of drawer ("standard", "custom" or



"sandwich") depending on the mechanical configuration of the drawer itself, and then press **ENTER** to save the selection. The result will appear immediately on the display bar. If the configuration is correct, the wording associated with each selection will be centred with regard to the partitions that delimit each selection. If you select the "custom" drawer, you must enter the number of display bar characters reserved for each drawer selection (in this case, the result will again appear on the display bar).

Enable drawer display: ticking this box enables the presence of drawer displays

Display contrast: set the contrast of the price display bar. The default value is 9 and the range is 1 to 16.

Display product description with door open: if the box is ticked, the previously programmed description will be displayed in correspondence with each selection when the main door is opened using the "VMC-configurator live" tool.

It is then possible for each drawer display bar to tick the box in order to enable presence.

Backlit drawer display: for each price display bar, the back-lighting value in standby mode is set: The cursor can be used to make four possible settings: maximum brightness value 100%; brightness value 75%; brightness value 50% and minimum brightness value 25%.

Display mode with promotional messages: sets the option for displaying promotional messages. The latter are text strings displayed on the bar display in correspondence to each product in alternation with the



price of the product. The text can be entered using the **Display Messages** icon in the **Selection Management** menu

Set the promotional message display mode using the drop-down menu; ON (always on) OFF (always off) FLASHING (backlit flashing) TEXT (flashing text).

Similarly, you can set the display mode for displays that do not contain promotional messages (**Display mode without promotional messages**).

The next required parameter is the time, in seconds, to display the promotional messages.

The last parameter is the **price display time**, i.e. the time for which the product price is displayed.

















*N.B.: With SPIRALS SLAVE connection enabled (see "Slave enable" under the **Settings menu**),*



*you can access the same parameters for the SLAVE machine using the **Slave programming icon** displayed in the main menu*



9.1.7 MANAGING SELECTIONS

	Quit and return to previous screen
	Read and store machine configuration
	Allows the enabling of certain functions such as sequential selections, the presence of devices for children and menus
	Used to set the prices of selections
	Used to insert promotional messages
	Used to enter a product code, stock level and capacity
	Used to inhibit requested selections
	Used to enable or disable selection photocells and set the quarter-turn, etc. for selection
	Allows the enabling of pushers for selections and to set the product size
	Used to set which selections are sequential
	Used to set heating times if a Wave Module is present
	Allows you to set on which selections to apply the child block
	Used for menu management (sale of product groups)
	Used to merge selections to be activated simultaneously (spirals in parallel)



9.1.7.1 GLOBAL PARAMETERS

This window allows certain functions to be enabled:

Sequential selections: this enables sequential selections or setting the dispensing of the same type of product to ensure uniform and progressive emptying of the drawer, regardless of the choices made by

customers. The selections can be set by selecting the icon  under the **Selection Management** menu

Enable menu: it is also possible to enable the menu function in order to sell groups of products (up to a

maximum of 3) by entering a single icon. The menus are managed by selecting the icon  under the **Selection Management** menu

Under-age device it is possible to enable possible device intended to restrict sales to minors ("Enable" from the drop-down menu). This is the preference if the device installed integrates electrical contact management timing function.

If this device is not fitted, select "Timed activated" from the drop-down menu and then set the timing (in seconds) on the "timed under-age prohibition device" bar



The selections subject to sales restrictions can be set by selecting the icon  under the **Selection Management** menu

ELECTRICAL CONNECTION OF THE CHILDPROOF DEVICE:

The connection must be made between a normally-open contact of the childproof device and the 2 pins of connector JP2 connector on the main board, shown in the figure.



Main board

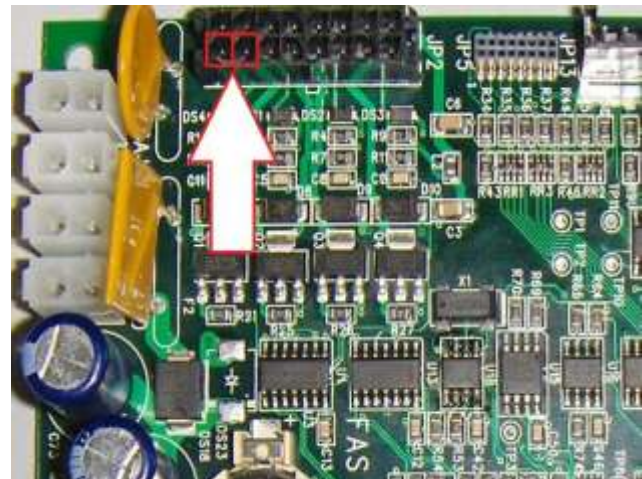

Detail of connector JP2

Use connector type Molex micro-fit 3.0 part no. 43025-1600 for the connection.



9.1.7.2 PRICES

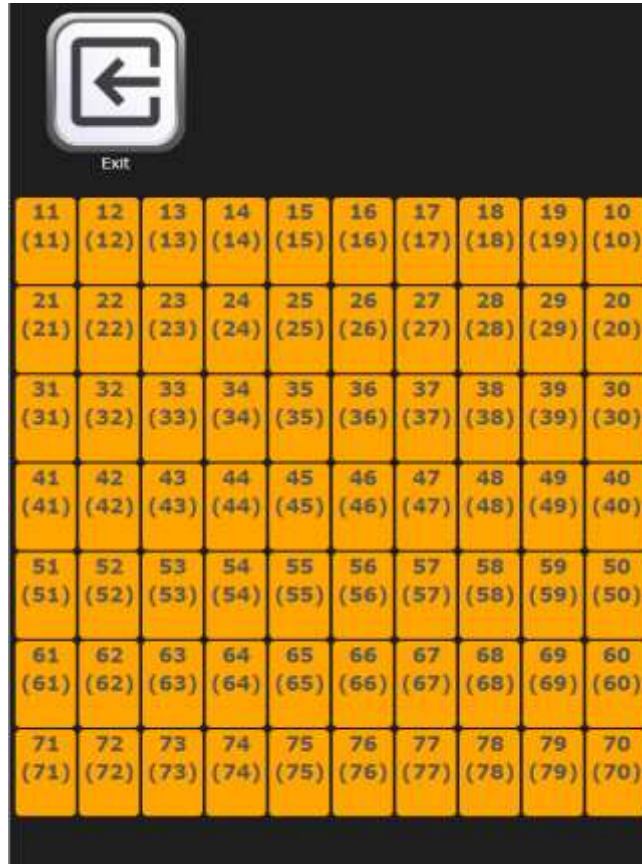

Access each selection by clicking on the corresponding spiral from the screen displayed. Depending on the communication protocol with the payment system, the price line and up to three different prices can be set:

Price 1: full price





Price 2: discount price based on the discount mode set in the **Settings**

Price 3: price for third price table (MDB only)

The number of the corresponding price line is shown in brackets under the selection number.

After setting the price, it can also be applied to the entire drawer or the entire machine by ticking the appropriate box

N.B.: With SPIRALS SLAVE connection enabled (see “Slave enable” under the  Settings menu),

you can access the same parameters for the SLAVE machine using the  Slave programming icon displayed in the main menu





9.1.7.3 DISPLAY MESSAGES

Access each selection by clicking on the corresponding spiral using the screen display



After entering the text of the promotional message, it can also be applied to the entire drawer or the entire machine by ticking the appropriate box

N.B.: With SPIRALS SLAVE connection enabled (see “Slave enable” under the  Settings menu),

you can access the same parameters for the SLAVE machine using the  Slave programming icon displayed in the main menu



9.1.7.4 PRODUCT MANAGEMENT

Access each selection by clicking on the corresponding spiral using the screen display



You can then enter:

- Product code (8 digits)
- Capacity
- Low stock level

This data can be read via the Audit file (using the WiFi connection or via the available connection ports: see



paragraph **Audit**)

After setting these values, they can also be applied to the entire drawer or the entire machine by ticking the appropriate box.

N.B.: With SPIRALS SLAVE connection enabled (see “Slave enable” under the  Settings menu),

you can access the same parameters for the SLAVE machine using the  Slave programming icon displayed in the main menu



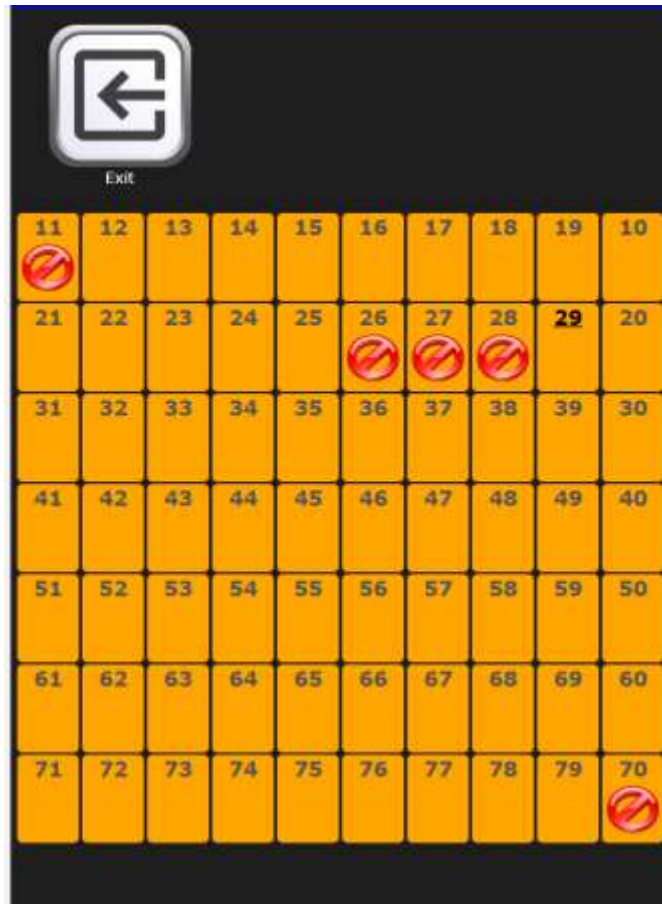

9.1.7.5 PREVENT SELECTIONS

Access each selection by clicking on the corresponding spiral using the screen display



After deciding whether to disable the selection or not, these settings can also be applied to the entire drawer or the entire machine by ticking the appropriate box

The disabled selection has this symbol  displayed under the number.

N.B.: With SPIRALS SLAVE connection enabled (see “Slave enable” under the  Settings menu),

you can access the same parameters for the SLAVE machine using the  Slave programming icon displayed in the main menu



9.1.7.6 PHOTOCELLS

Access each selection by clicking on the corresponding spiral using the screen display



Once you have decided whether or not to enable the photocells for selecting and quarter-turn or multi-step selection mode, these settings can also be applied to the entire drawer or the whole machine by ticking the appropriate box.

When the photocells are enabled, the symbol  is displayed on the selections chosen

When quarter-turn or multi-step mode is activated, the symbol  is displayed on the selections chosen

N.B.: With SPIRALS SLAVE connection enabled (see “Slave enable” under the  Settings menu),

you can access the same parameters for the SLAVE machine using the  Slave programming icon displayed in the main menu



9.1.7.7 PRODUCT PUSHERS

Access each selection by clicking on the corresponding spiral using the screen display



After deciding whether or not to enable the product pusher for selection, it is possible to indicate the thickness in millimetres of the product loaded (value used if photocells are not enabled that indicates when the product pusher should stop) and also apply these settings to the entire drawer or the entire machine by ticking the appropriate box

When the pusher is enabled, the symbol  is displayed on the selections chosen

N.B.: With SPIRALS SLAVE connection enabled (see “Slave enable” under the  Settings menu),

you can access the same parameters for the SLAVE machine using the  Slave programming icon displayed in the main menu



9.1.7.8 SEQUENTIAL SELECTIONS:



Once the management of sequential selections has been enabled inside the **Global Parameters** icon, the selections that are to be sequential can be managed using the layout displayed.



The selections chosen to be sequential will be indicated graphically by yellow circles instead of a green circle

*N.B. : With SPIRALS SLAVE connection enabled (see “Slave enable” under the  **Settings menu**),*

*you can access the same parameters for the SLAVE machine using the  **Slave programming icon** displayed in the main menu*



9.1.7.9 HEATING TIMES



After enabling microwave module management in the **Settings** icon, heating times can be set if a Wave Module is present using the screen displaying these selections. Values can be set from 0 to 180 seconds.





9.1.7.10 CHILD BLOCK



Once child block device management is enabled inside the **Global Parameters** icon, it is possible to type on the selections to be blocked to minors using the layout displayed.

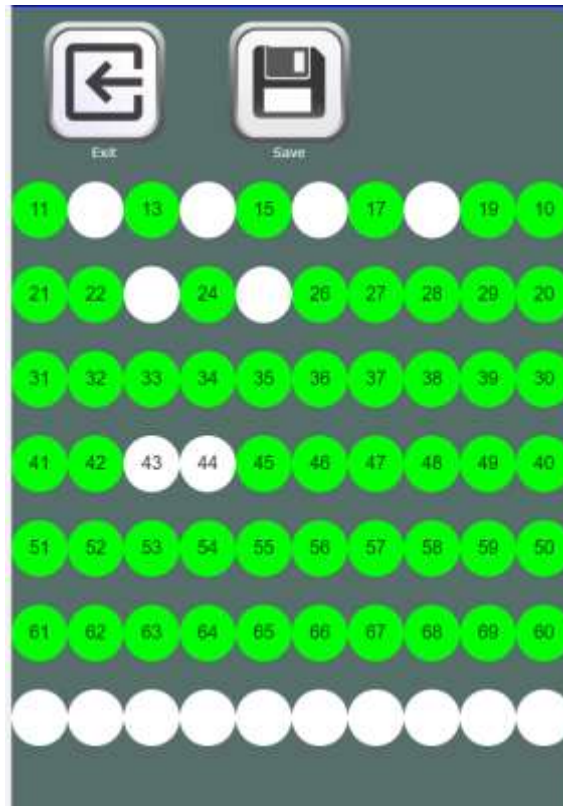

The selections chosen to be blocked for minors will be depicted graphically with white circles instead of a green circle (selection normally enabled)



9.1.7.11 MENU MANAGEMENT

The required menus (max 9) can be managed once the possibility to create menus by ticking the pertinent



box inside the **Global Parameters** icon has been enabled.

It will be possible to enable the required menus and to associate the selections (even more than one for each choice) that will compose the menu

Then the price line (Price holding mode) or three different prices can be set:

Price 1: full price



Price 2: discount price based on the discount mode set in the **Settings**

Price 3: price for third price table (MDB only)



9.1.7.12 SPIRALS IN PARALLEL

This function is used to combine two selections from the same drawer so that they operate simultaneously and thereby dispense products that take up more space than a standard double spiral (150 mm). Once the selections to be combined have been chosen, type on the number of the first selection which will then start flashing while waiting for the second selection to be entered. Once the second selection has also been made (it is possible to choose any number present on the same drawer as the second selection), both will turn green and the same selection number will be associated with both (the same as the number of the first selection chosen)

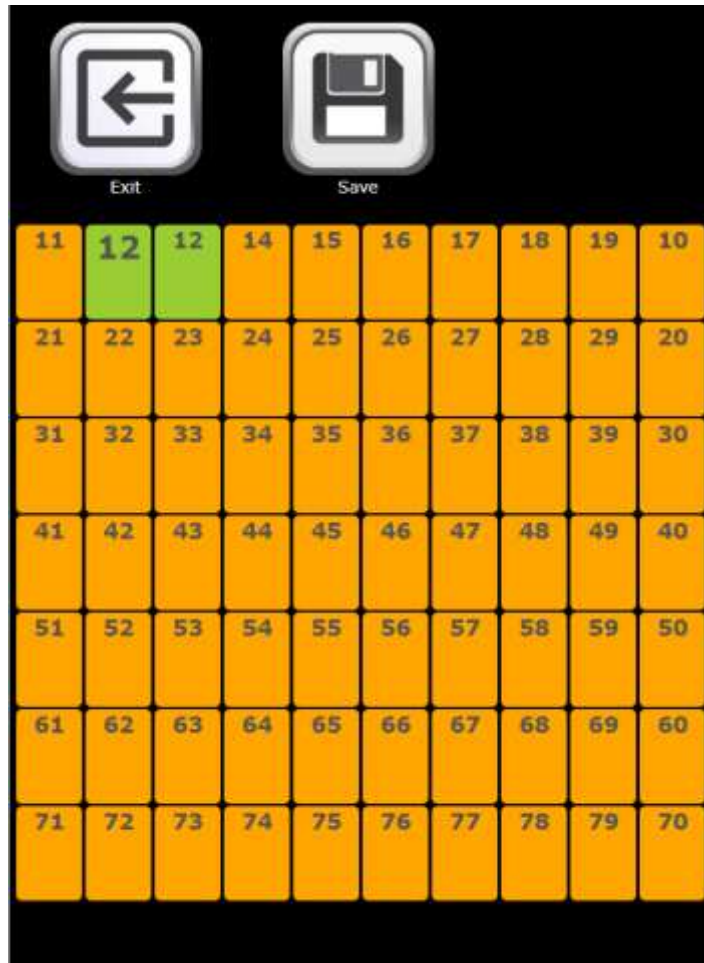



9.1.7.13 BOTTLE DISPENSERS

This function is used to manage the selections presented by the HCB bottle dispenser module using the layout displayed illustrating the selections present. After deciding whether to enable the bottle dispenser or not, these settings can also be applied to the entire drawer or the entire machine by ticking the appropriate box



When the bottle dispenser is enabled, the symbol  is displayed on the selections chosen

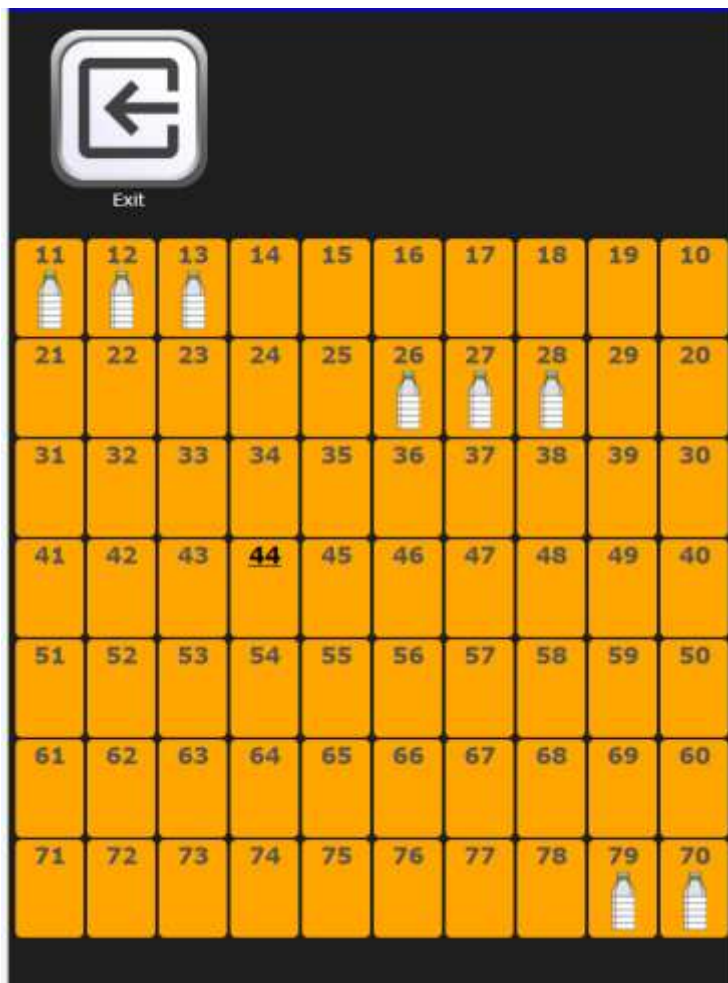



9.1.8 CLONING

It is possible to export machine cloning or import cloning from another DA using a USB key inserted into one of the sockets on the card highlighted in the photo



The file created has the “filename.DAT” extension

To import such data, simply select the desired file stored on the USB key and it will be copied into the machine.



9.1.9 AUDIT

The control board is equipped with an RS232 socket. The I/O connector is a 9-pin male that uses the following pins:

- Pin 2 VMC Tx - Pin 3 VMC Rx - Pin 5 Ground -Pin 7 CTS

Enable Conventional Audit: enables the audit via a third party terminal/modem (FAScloud is not used)

Enable sending events: ticking this box enables sending of all events (door closed, errors, etc.) to the conventional audit (otherwise only EVA DTS data will be managed)

Audit protocol: by selecting EVA-DTS DDCMP from the menu the machine communicates with the outside world via the infra-red interface 082925 (IRDA interface) or through physical connection on the 9-pin connector, according to the specifications of the EVA-DTS protocol, vers. 6.0.

If the command is set DEX UCS, the machine communicates with the outside world with the DEX-UCS protocol.

Connection port: the machine offers the choice of the type of connection: Infra-red interface (IRDA OUTPUT) or cable interface on the 9-pin connector on the board (RS232 OUTPUT).

Transmission speed: you are offered the choice of transmission speed, which must be consistent with the setting of the 082925 board in the case of infra-red connection (see related instructions). The selection is made by scrolling through the various speed options from the drop-down menu

Peripheral address: the machine prompts you to enter the address of the peripheral: enter the desired value

Negotiated speed: enables the possibility of speed negotiation between the machine and the terminal (option valid only for cable connection)

Asset number: this is an 8-digit machine identification numeric code. This will then be entered in the Audit file for machine identification

Disable sending single sales event: ticking the box blocks sending the event generated by each individual sale (used to avoid managing very large amounts of data)

Disable sending temperature event: : ticking the box blocks sending the event generated by reading the internal temperature probe of the D.A. every 15 minutes (used to avoid managing very large amounts of data)













9.1.10 OUTPUT TEST



It is possible to test certain outputs from the power board in order to verify the functionality of these outputs or the components connected to them.

Select the switch corresponding to the required output to activate or deactivate the output (the status LED will indicate activation or deactivation); it is then physically possible to verify the effective functionality of the connected component (e.g. switching on the refrigerator unit compressor, switching on tangential fan, switching on of the lighting power LEDs, etc.).



9.2 CONTROL PANEL

	Quit and return to previous screen
	Update interface type
	Update customisation
	Update configuration
	Update multimedia
	Update engine
	Identification parameters
	Reset engine
	Used to set date and time
	Allows access to tablet settings

	Do not use
	It allows you to verify the connection and to read the diagnostics if there is no connection
	Used to set the home screen video in full screen mode



9.2.1 UPDATE INTERFACE TYPE

INTERFACE: Identifies an interface in terms of graphics (colours, layout, button style, etc.), operation (category/selections, alphanumeric keypad, icon selection, sequence of screens to reach product selection).



After setting the correct interface code in the ID parameters, use the icon to update the interface type.

The update can be performed remotely (if the tablet is connected to the internet) or locally, in which case the interface file must be pre-loaded onto the tablet using a USB pen drive.

Remote upgrade is completely automatic: the tablet connects to the specific server, downloads and installs the file and then runs the interface.

The interface file is a compressed file (.zip extension) the name of which is formed from any alphanumeric sequence of up to 20 characters (e.g. INTERFACCIA00000003.zip). To load this file up to the tablet after copying it to a USB pen drive, proceed as follows:

Insert the key into one of the USB ports highlighted in the photo.



Select the "copy from USB to local" icon to download the file to the tablet; then select the "from local"



icon. The interface will be installed and run automatically.



9.2.2 UPDATE CUSTOMISATION

CUSTOMISATION: For a given interface, the modifiable elements of the interface itself can be customised.

For example:

Determines how many and which languages are used in an interface.

Defines the product database and ingredient lists.



After setting the correct "customisation code" in the ID parameters, use the icon to update the customisation

Once again in this case, the update can be performed remotely (if the tablet is connected to the internet) or locally, in which case the customisation file must be pre-loaded onto the tablet using a USB pen drive.

Remote upgrade is completely automatic: the tablet connects to the specific server, downloads and installs the file and then runs the interface updated with the new customisation.

The interface customisation file is a compressed file (.zip extension) the name of which is formed from any alphanumeric sequence of up to 20 characters (e.g. PERSONALIZZA000002.zip). To load this file up to the tablet after copying it to a USB pen drive, proceed as follows:

Insert the key into one of the USB ports highlighted in the photo.



Select the "copy from USB to local" icon to download the file to the tablet; then select the "from local"



icon. The customisation will be installed and run automatically.



9.2.3 UPDATE CONFIGURATION

CONFIGURATION: identifies the machine configuration, i.e. the parameters set, prices, etc. It is therefore equivalent to the cloning file.

Also in this case, the update can be performed in remote mode (if the tablet is connected to the internet) or in local mode; in this last case the configuration file must be pre-loaded onto the tablet using a USB pen drive. The remote upgrade is completely automatic: the tablet connects to the specific server, downloads the file, installs and then runs the new configuration.

The configuration file is a compressed file (.zip extension). Its name comprises any alpha-numeric sequence of max 20 characters (E.g. CONFIGURAZIONE000002.zip). To load this file up to the tablet after copying it to a USB pen drive, proceed as follows:

Insert the key into one of the USB ports highlighted in the photo.

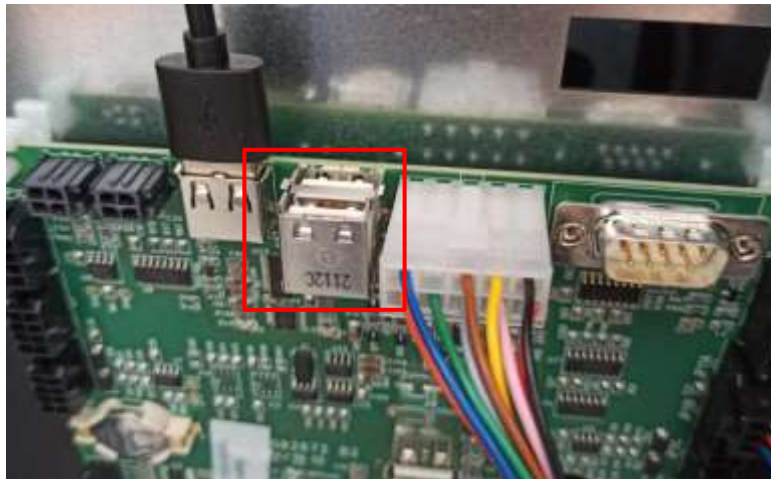

Select the "copy from USB to local" icon



icon. The configuration will be installed and run automatically.



9.2.4 UPDATE MULTIMEDIA

MULTIMEDIA: Identifies the particular multimedia "collection" used by the machine (series of videos, images).



After setting the correct "multimedia code" in the ID parameters, use the icon to update the multimedia collection.

Once again in this case, the update can be performed remotely (if the tablet is connected to the internet) or locally, in which case the multimedia file must be pre-loaded onto the tablet using a USB pen drive.

Remote upgrade is completely automatic: the tablet connects to the specific server, downloads and installs the file and then runs the updated interface with the new multimedia content.

The multimedia content file is a compressed file (.zip extension) the name of which is formed from any alphanumeric sequence of up to 20 characters (e.g. MEDIA000002.zip). To load this file up to the tablet after copying it to a USB pen drive, proceed as follows:

Insert the key into one of the USB ports highlighted in the photo.

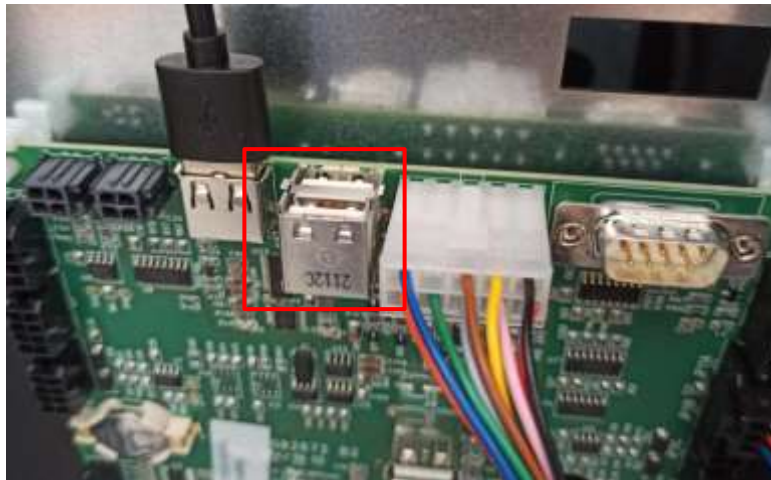

Select the "copy from USB to local" icon to download the file to the tablet; then select the "from local"



icon. The multimedia collection will be installed and run automatically.



9.2.5 IDENTIFICATION PARAMETERS

Machine ID: device identification code (enter the serial number indicated on the FAS label)

Client: enter the client code used to access the telemetry site

Password: entered in the password box, which allows the machine to connect to the telemetry site

Model: enter the machine model (e.g. FASTER)

Machine serial number: this is an 8-digit machine identification numeric code. This will then be entered in the Audit file for machine identification

The interface, configuration, personalisation and multimedia codes (i.e. the names that were given to the files) can then be entered. (Zip files to be loaded in the machine)

Server: address of the telemetry site

Unit: identifies membership of a particular machine unit (e.g. machines 2nd floor)





Machine location: the physical position of the machine (e.g. address)

User: leave default data

Currency symbol: it is possible to enter the currency symbol that will appear on price displays (if present) and the tablet next to the price of the selection (the symbols managed are € and £).



9.3 SALES DATA

	Quit and return to previous screen
	Display totals regarding the transactions carried out since the initialisation of the machine
	Display totals regarding the transactions carried out but unlike the values displayed with the previous icon, they can be reset
	Displays sales data for each selection
	Used to reset sales data by entering an access code. CODE: 1221



9.4 EXPORT EVA-DTS DATA

Used to export EVA-DTS data to a USB key

N.B.: use the USB port on the HUB card of choice between the 2 shown in the photo

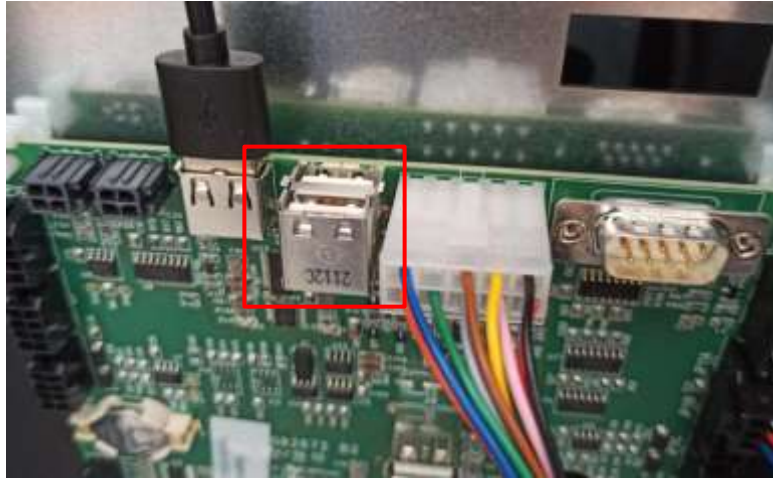

UPDATE MAIN-BOARD

Used to update main card software

N.B. Use the USB port in the card shown in the photo

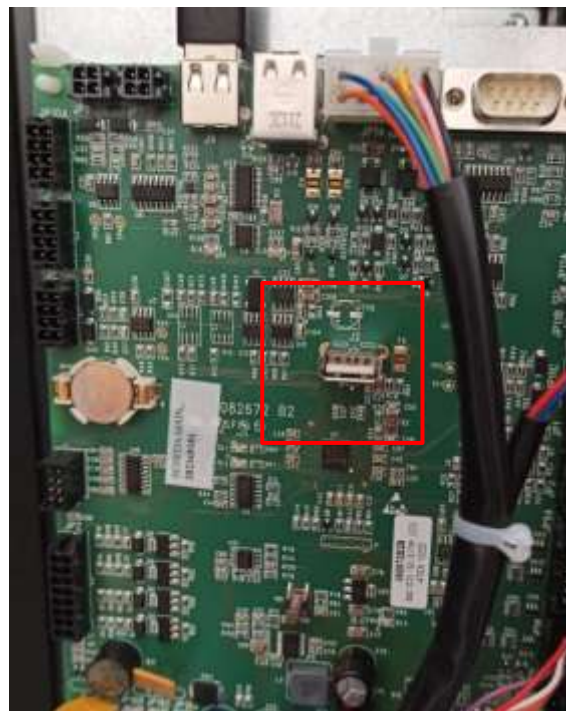



9.5 SALE TEST

This icon gives access to a screen showing all the dispenser selections.

Active selections will be highlighted in green. Touching an individual selection activates the corresponding spiral motor. Selections that are out of service will be highlighted in red while those not in their “home position” (having made a quarter turn) will displayed orange. Selections can be reset (by rotating them) each time the relative number is pressed; alternatively, all selections can be reset at the same time by selecting the Reset position



icon

ATTENTION: Rotating the selection to reset it with the door open could cause the product to fall to the ground.





It is also possible to reset all errors in the machine by selecting the Reset errors icon



*N.B.: With SPIRALS SLAVE connection enabled (see “Slave enable” under the **General Enables menu**), you can access the same parameters for the SLAVE machine using the **Slave programming** icon displayed in the main menu*



9.6 SHOW PHOTO

	Quit and return to previous screen
	Allows you to view the uploaded photo on the vending machine using the telemetry site
	Allows you to enlarge the image uploaded
	Allows you to view the QR code corresponding to the uploaded image

This sub-menu allows you to view the image (the photo of the vending machine configuration) previously uploaded via the telemetry site.



By selecting the **QR code** icon, you can also upload the photo to your mobile phone using any scanning app.

10 ERROR CODE TABLE

ERROR CODE	SUB-CODE	FAILURE
01	Number selection code	Motor blocked (the spiral does not rotate)
02	Number selection code	The spiral does not complete rotation / time out of the HCB knob rotation (7 sec)
05	Number selection code	Motor disconnected
07	Number selection code	HCB pusher time out (15 sec)
09	Number selection code	Possible microswitch defect or spiral motor wiring defect
10	(*) 38 - 39	Internal temperature feeler faulty
11	(*) 38 - 39	Evaporator probe faulty
16	(*) 33 - 38 - 39 -117	Error communication with peripheral (electric panel-Hub board)
17	(*) 38 - 39	Communication break during sale cycle without credit collection
18	(*) 38 - 39	Communication break during sale cycle with credit collection
30	(*) 38 - 39	Fridge safety has intervened
31	(*) 38 - 39	Photocell test error.
32	(*) 38 - 39	Photocell calibration error
33	(*) 38 - 39	
39	(*) 38 - 39	Photocell safety
51	(*) 38 - 39	Interruption of peripheral connection at the beginning of the sale cycle.
55	/	Payment system out of service.
61	Number selection code	Motor blocked (the spiral does not rotate) SLAVE A
62	Number selection code	The spiral does not complete the rotation SLAVE A
65	Number selection code	Motor disconnected SLAVE A
69	Number selection code	Possible microswitch defect or spiral motor wiring defect SLAVE A
91	Number selection code	Selections not reset.
93	/	Communication Error between the machine and Audit device

(*) Key:

33 = Photocells
 38 = Spirals Master
 39 = Spiral Slave
 117 = Hub board

11 ADJUSTMENTS

11.1 SPIRALS

	<p>Most of the products can be sold without problems when the end of the spiral is placed on hour 6. To modify the end, draw the spiral forward until the base of the spiral support will come out from the pit; then turn the spiral in the wished position and put it again into the pit.</p> <p>Each spiral can be turned each time of 45°.</p> <p>CAUTION: when carrying out this operation ensure that the motor micro cam is always in the standby position. To do this simply carry out several dispensing operations in the "TEST VEND" mode (see paragraph FUNCTION/PROGRAMMING KEYBOARD).</p>
---	---

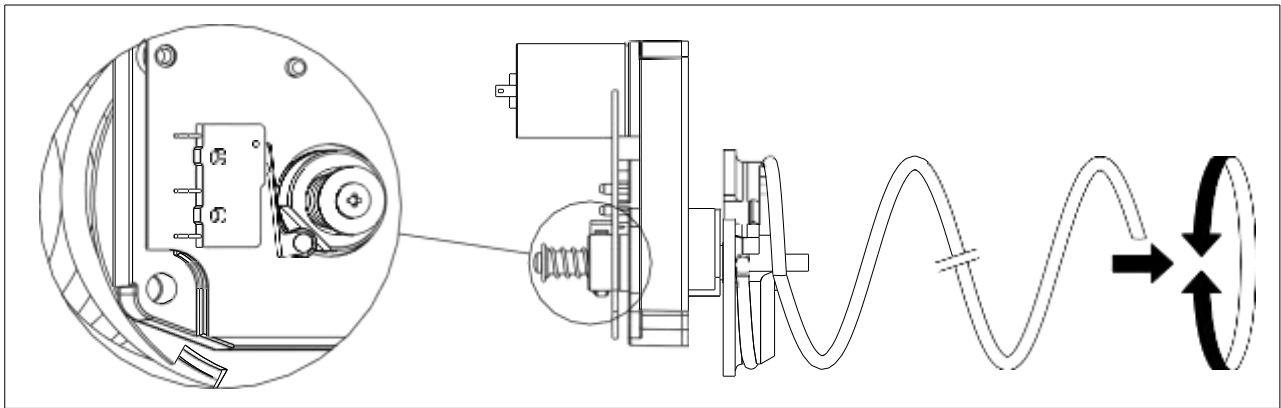

11.2 PROCEDURE FOR REPLACING SPIRALS AND EXPELLER MOTOR GROUP

	<p>The machine is supplied with drawers with spirals of different diameters and pitches. To vary their quantity or their order, proceed as follows:</p> <ul style="list-style-type: none"> • Switch the machine off via the main switch, and take out the plug. • Open the main door. • Pull out the drawer on which you have to vary the spiral. • Switch off and take out the group motor-spiral. • Take out the spiral from the plastic support (lever between spiral and support) and replace with the other spiral or with the other expeller motor group. • Fit up the new spiral group reversing the above operations. After having finished this operation, make sure that the end of the spiral is put on hour 6, otherwise see paragraph "SPIRALS".
---	---

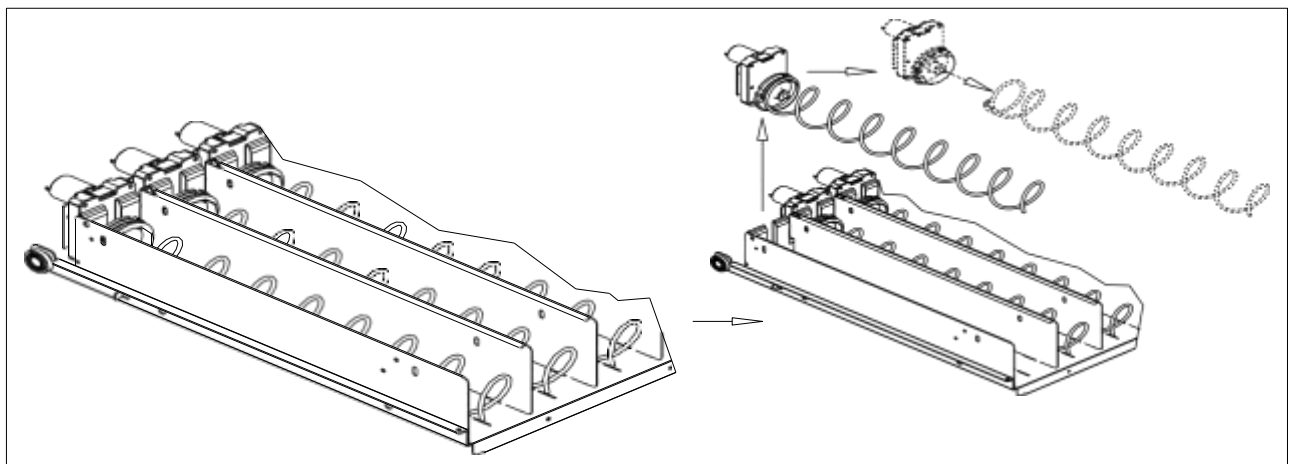

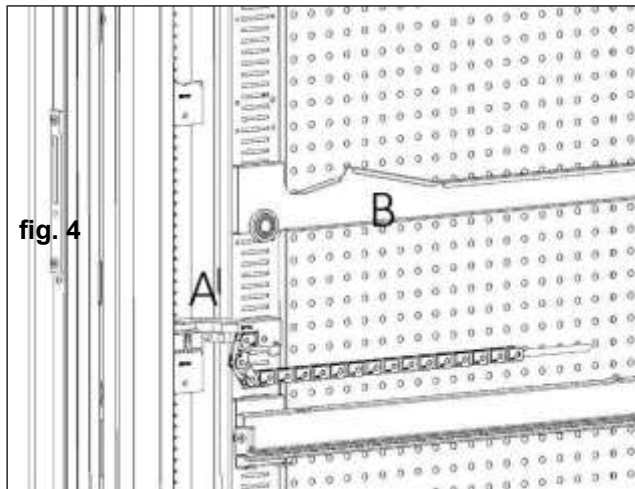
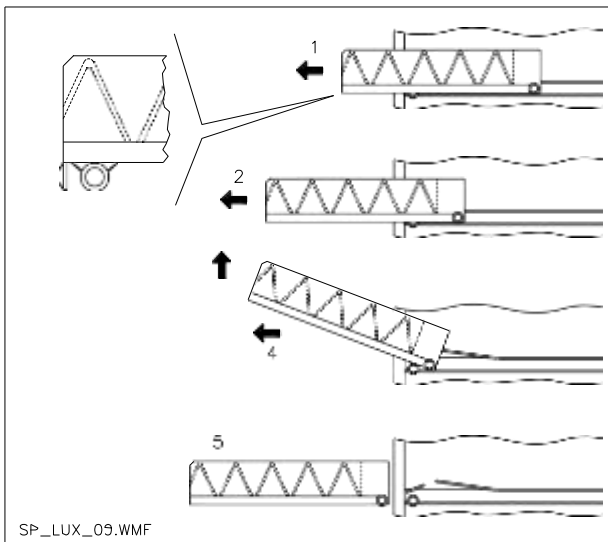

fig. 4



SP_LUX_09.WMF

fig. 5

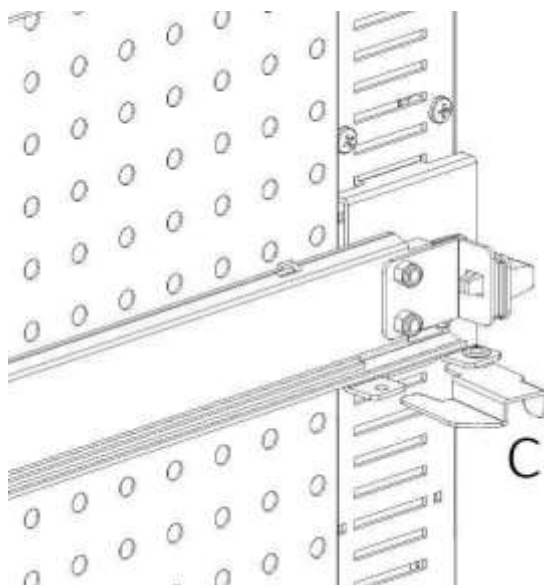

fig. 6

11.3 PROCEDURE FOR REMOVING THE DRAWERS

To replace the drawer proceed as follows:

- Switch off the machine by means of the main switch and pull out the power plug.
- Open the main door.
- Remove the electric connector -A- .
- Pull out the drawer by overcoming the resistance exerted by the positioning spring (pull gently).
- Pull the drawer until it hits the stop, pull it upwards, rotate it downwards until it is released from the guide, then finally remove it from the machine.

To mount a drawer proceed as follows:

- Insert the drawer.
- Push the drawer until it engages in the locked position.
- Insert the electric connector -A-.
- Close the main door.
- Energise the machine by means of the main switch.

11.4 MODIFYING THE TRAY NUMBER

Vending machines with 6 drawers can be transformed into machines with 7 drawers by proceeding as follows:

- Switch off the machine by means of the main switch and pull out the power plug.
- Pull out all the drawers from the vending machine.
- Move the guides ref. . B (the last one on the bottom is already in the correct position consequently it does not need to be moved). To move the guides, open the fastener, ref. C, and then turn the guide to remove it and position it at the desired height.
- Move the connectors, set. A, placed on the bottom of the cabinet.
- Add a pair of guides.
- Mount 7 drawers and check that the connectors are plugged in correctly.
- Set the new prices.

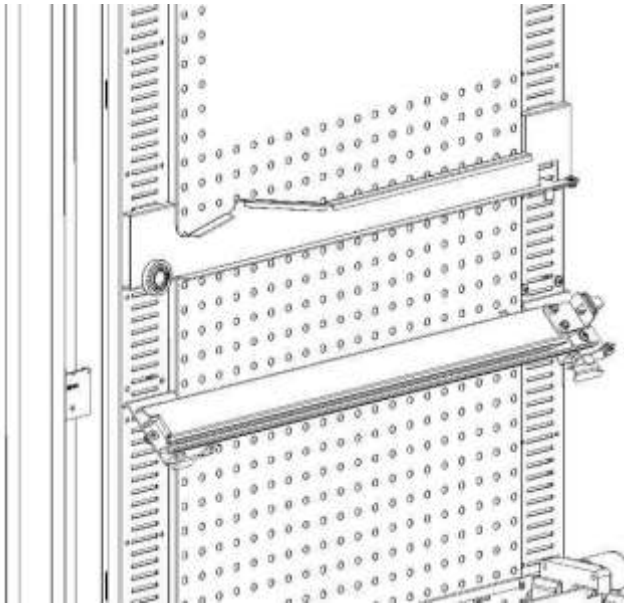

fig.7

11.5 PROCEDURE FOR CHANGING THE TEMPERATURE MANAGEMENT SIDE-PANEL

In order to change the stratification of the temperatures inside the machine it is necessary to use the proper side-panel as explained in **Chapter 3**.

To change the side-panels in the vending machine:

- remove the drawers as explained previously
- remove all the guides, ref. B
- act on the top part of the perforated side-panel by pulling it towards the inside of the machine as in **fig. 8**.
- It is now possible to extract the side-panel and fit the desired one, following the inverse procedure.

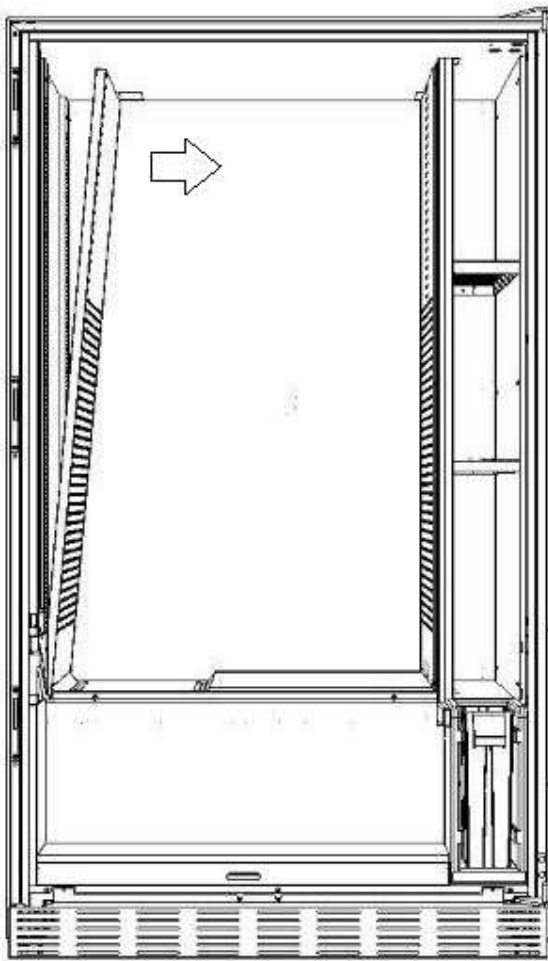
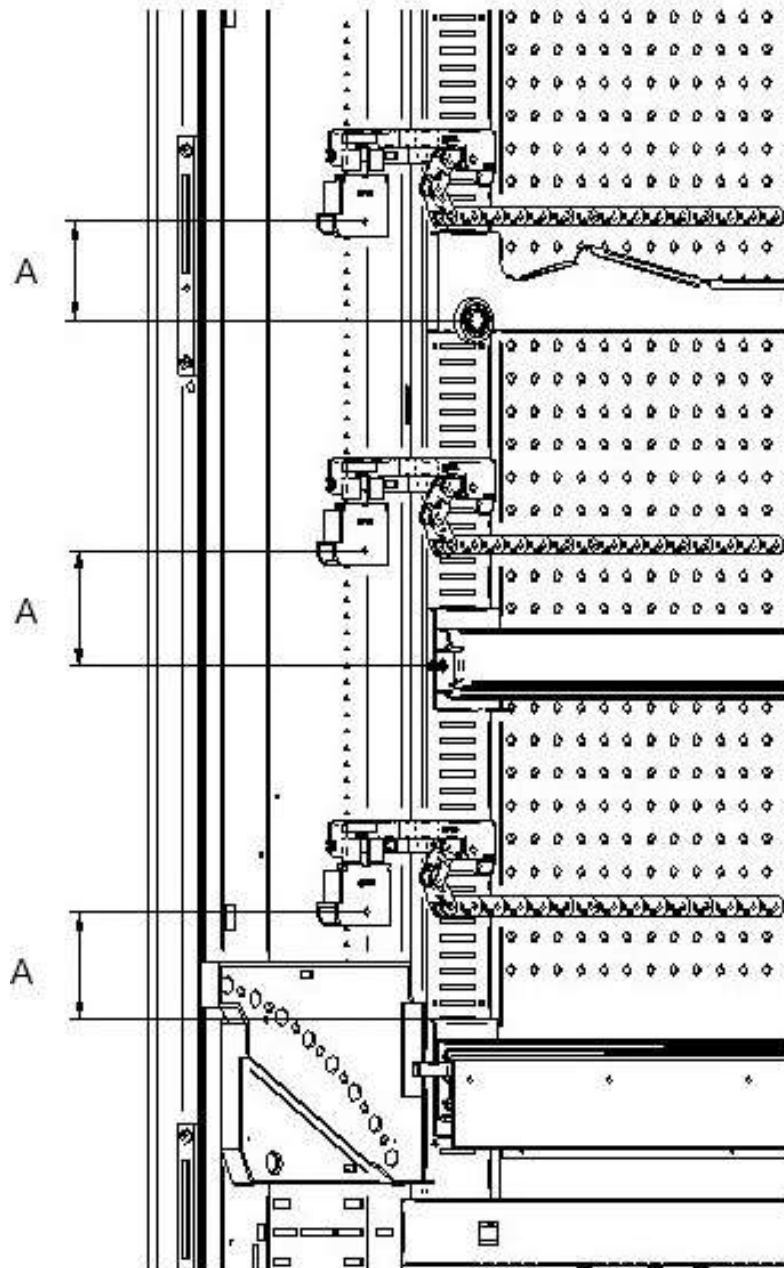

fig.8

11.6 FITTINGS FOR FASTENING TRAY WIRING ⚠



If there is a change in the number of drawers installed in the automatic vending machine, or if their position is rearranged, it is advisable to adhere strictly to the recommended measurements set out in the following table for a correct winding of the wiring when the drawer is pulled out:

TYPE OF DRAWER/RUNNER	DIMENSION "A" (mm)
Drawer with standard runner	60
Drawer with reinforced runner	70
Any drawer with bottle discharge bar	110
HCB drawer	66

11.7 INSTRUCTIONS FOR CONVERTING THE TRAYS

from one large space to two small spaces.

- Switch the machine off via the main switch, and take out the plug.
- Open the door.
- Remove the neon cover.
- Pull out the drawer to be modified.
- Remove the spiral + motor unit set.1.
- Remove the drawer set.3.
- Replace the spiral with large diameter with a spiral with small diameter.
- Insert the spiral with small diameter + motor unit in the left hand slot on the support set. 4.
- Insert the new spiral with small diameter + motor unit in the right hand slot and connect it to the wiring on the drawer.
- Add the new divider in between the two spirals set. 2.
- Install the new price and selection labels.
- Insert the modified drawer and make sure that the connector is plugged in.
- Programme the new selections at the desired sale price.
- Test the new selections to ensure that they work correctly.

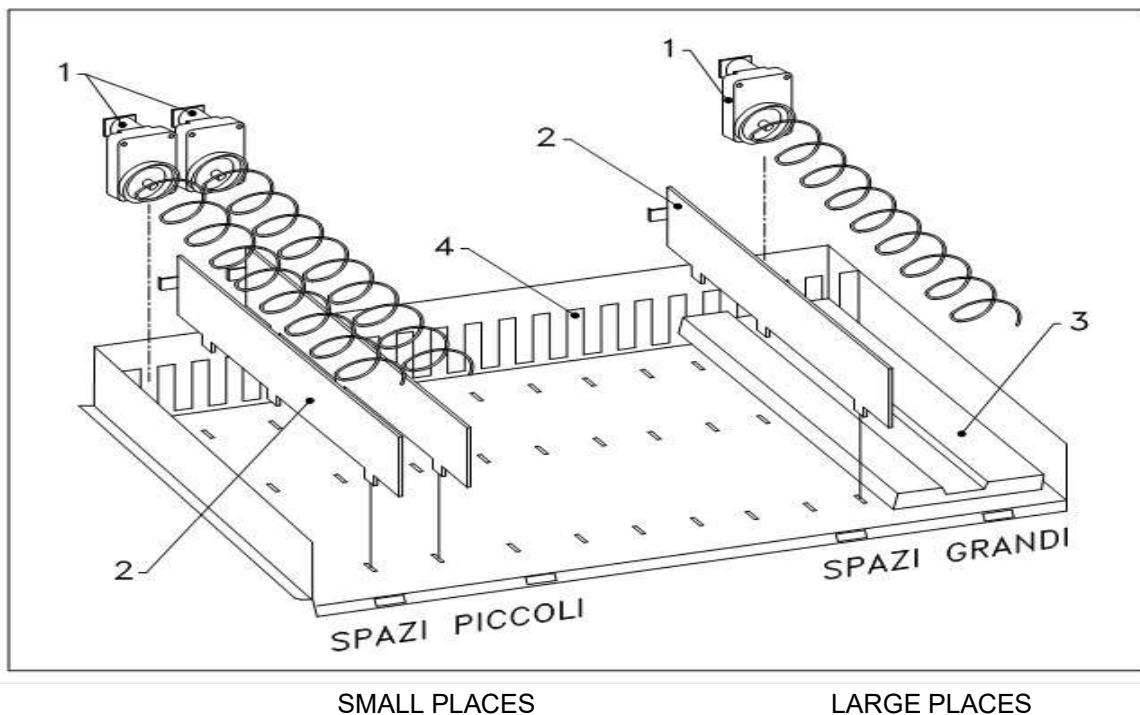

from two small spaces to one large space.

- Switch the machine off via the main switch, and take out the plug.
- Open the door.
- Remove the neon cover.
- Pull out the drawer to be modified.
- Remove the spiral + motor units set.1.
- Put one spiral + motor unit aside and in the other one replace the spiral with small diameter with a spiral with large diameter.
- Remove the divider set.2.
- Insert the drawer set.3.
- Insert the spiral with large diameter + motor unit in the central slot of the support set. 4.
- Install the new price and selection plates.
- Insert the modified drawer and make sure that the connector is plugged in.
- Programme the new selections at the desired sale price. **NOTE: In the large space selections, the selection numbers are odd numbers. E.G.: Selections A 1 and A 2 converted to a single compartment become a single selection A 1.**
- Test the new selections to ensure that they work correctly.

11.8 ACCESS TO THE ELECTRIC PANEL AND REFRIGERATION UNIT

To access the electric panel or the refrigeration unit proceed as follows:

- Switch the machine off via the main switch, and take out the plug.
- Open the door.
- Use a Philips screwdriver to undo the two screws that fasten the product collection pocket to the cabinet. Remove the pocket.
- To remove the refrigeration unit, lower the two levers located on the side of the evaporator box, ensure that the gasket positioned on the top edge of the evaporator box is not attached to its lodging, pull the special handle. CAUTION: beware of the cables.
- On the basis of Regulation 517/2014/EC, the refrigerator units will use alternative refrigerant gases. The refrigerator unit bears the necessary labels for recognising the type of gas used, and its charge. The refrigerator unit is fully airtight; any replacements that need to be made on the machine will therefore require a simple mechanical operation. If the professional operator wants to handle the repair personally, he/she must first of all be sure to have the necessary knowledge and equipment for the indicated type of gas



Control panel: When the product collection pocket is removed the entire vending machine remains energised. Total isolation from the electric power supply is only obtained when the plug is removed from the external circuit breaker switch. Consequently, all operations required by the vending machine without the protection of the product collection pocket, must only be carried out by qualified personnel who are aware of the specific hazards which this condition involves.

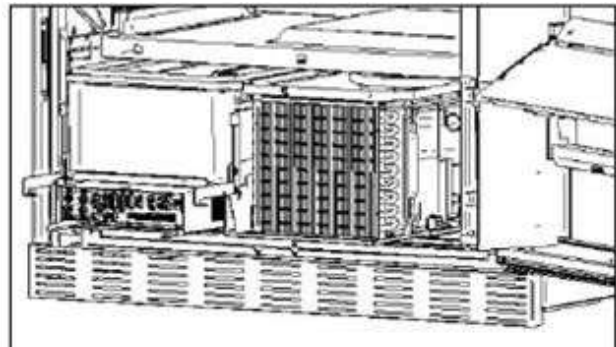
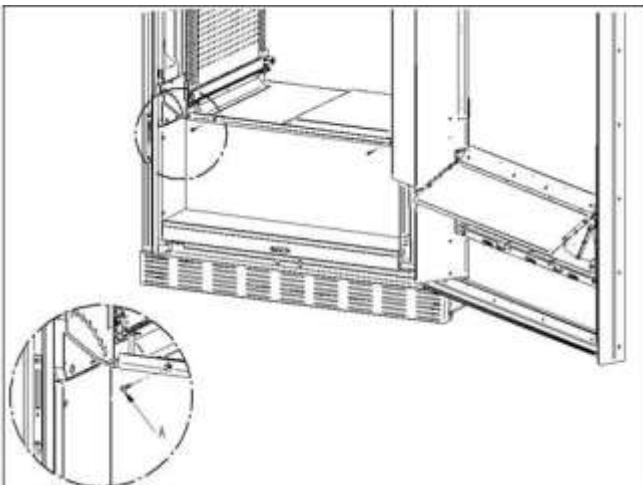

• BOTTLE UNLOADING KIT

The bar can be placed in 6 different holes depending on the type of bottle loaded

CAUTION: the bottle discharge bar must not be used to pull-out the drawer.

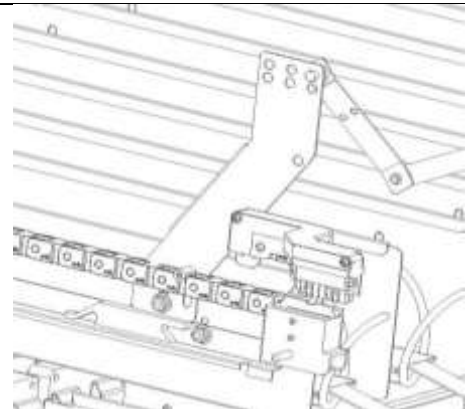

11.9 INSTRUCTIONS FOR REPLACING THE INTERNAL LIGHTING DEVICE



- Switch the machine off via the main switch, and take out the plug.
- Open the main door.
- Remove the cover from the light source.
- Replace the light source.
- Carry out the operations in reverse order to reassemble.

12 INSTRUCTIONS FOR CLEANING



Only persons with the knowledge and practical experience with the unit can perform these operations as they involve unit safety and hygiene.

Adequate recurring maintenance of machine grants its reliability in operation. This chapter is dedicated to maintenance operations and their frequency, which must in any case be considered indicative since they depend on various factors such as the type of products used, the climate conditions and in particular the humidity, etc. This chapter does not give an exhaustive description of all the maintenance operations. During maintenance vending machine has to be switched off. Do not wash vending machine with direct jets of water and high pressure. To avoid the risk of rust or chemical corrosion in general, the stainless steel and painted surfaces must be kept clean.

12.1 IMPORTANT POINTS FOR CLEANING

Use the cleaning products as instructed on the label. Do not use detergents which are too "aggressive" as they could damage some of the parts. The manufacturer declines all responsibility for damage caused by the improper use of such detergents or the use of toxic agents.

With sanitising products (chlorine-based detergents or similar products)	Inside cabinet (drawer zone), drawers, display window . Remove detergent, disinfectant and foodstuff residues with a damp sponge before restarting the machine.	At each reload, or at least every 5 days
With vacuum cleaner or compressed air	Remove the dirt from the condenser. Make sure there is an air gap between the front and back of the condenser. Always clean the inside of the cabinet after this operation.	every month
If this operation is not performed correctly, the refrigeration system could be seriously damaged.		

12.2 INACTIVITY

To prevent hazardous situations from arising at start up, suitable precautions must be taken when the machine will not be used for a long period of time. Here, a long period of inactivity is understood as a period exceeding one month.

For long resting period, it is necessary:

- To clean the machine thoroughly and to dry it;
- To check carefully for damaged or worn parts and to replace them;
- To check that the screws and bolts are securely tightened;
- To cover the machine after having stored it in a protected environment.

To re-set the machine at work, comply with the instructions given in the paragraph "Installation" of this manual and pay particular attention if food products are to be sold (see paragraph "Use of the vending machine for the sale of food products").